

* AGENDA *
LUDINGTON CITY COUNCIL MEETING

Municipal Building
Monday, August 27, 2012
6:30 pm

- 1.) Roll Call
- 2.) Invocation
- 3.) Pledge of Allegiance
- 4.) Approve Agenda
- 5.) Meeting Open for Public Comments
- 6.) Approval of Minutes - Regular Meeting - August 13, 2012
- 7.) Communications
- 8.) Committee Reports
 - a.) Finance
 - 1.) Payment of Bills
 - b.) Personnel
 - c.) Public Safety / Public Utilities
 - d.) Buildings & Licenses / Long Range Planning & Industrial Development
 - e.) Cemetery, Parks, and Recreation / Waterfront
- 9.) Communications from City Officials
 - a.) Mayor - Appeal of FOIA Decision - August 22, 2012 - FOIA Request Dated 8/14/12
 - b.) Mayor - Closed Session - Discuss McAdams Lawsuit
- 10.) Miscellaneous Business
- 11.) Adjournment

August 13, 2012

Regular meeting of the Ludington City Council held in the Council Chambers of the Municipal Building on Monday, August 13, 2011, at 6:30 o'clock p.m.

Present: His Honor Mayor John Henderson and Councilors Kaye Holman, Richard Rathsack, Wally Taranko, Les Johnson, Wanda Marrison, Nick Tykoski, and Gary Castonia.

Absent: City Manager John Shay who was excused.

Also present were City Attorney Richard Wilson, Police Chief Mark Barnett, Fire Chief Jerry Funk, City Treasurer Linda Rogers, and City Clerk Deborah Lusk.

Invocation was pronounced by Police Chief Barnett.

Pledge to the Flag was given.

Moved by Councilor Castonia, seconded by Councilor Tykoski, that the Agenda be approved as presented. Motion Carried.

The meeting was opened for public comments.

Lyla McClelland, City of Ludington, reminded the public about the upcoming Hazardous Waste pickup at the Mason County Road Commission Building on August 18, 2012.

Susan Boes, City of Ludington, commented that she supported Councilor Holman's Resolution for Local Proposal for ballot language to keep Mayor John Henderson in office.

C. Dale Bannon, City of Ludington, reminded City Council that the position to the right is always the honored position and the United States Flag is always honored to the right. He asked that the United States flag be moved to the honored spot on the deck of the Council Chambers. He then commented on the proposed Resolution for Local Proposal for ballot language changes to the term limit of the Mayor and stated that the original language was there for a reason. It is a good idea to honor our Mayor but not a good idea to change the writing as it is already written in the charter. He stated that if the City were to put this to a vote of the public and it was turned down this could be construed as a vote against the current mayor and he does not think anyone wants that either.

Tom Rotta, City of Ludington, commented that Mayor Henderson made reinstating the lifeguard program a cornerstone of his campaign in 2001. In June 2009, three lifeguards saved two teens at Stearns Park. He explained that the lifeguards provide life rescuing services which is why we have lifeguards at the beach. He then commented that a new transient dock was constructed at the Marina and then three months later, the budget called for not hiring lifeguards and raising rates for several city fees. There were no accolades for the heroic efforts of the lifeguards, no appreciation for the lifeguards doing summer projects, the Mayor just sat and listened as seven lifeguards were given pink slips. In 2010, Anthony Goldsmith, picture provided, visited Ludington and seeing two swimmers in trouble, he and his son jumped in by the breakwall to save these individuals. He drowned. If the lifeguards would have been in place, they could have saved this man. The police report he received through FOIA confirms this hypothesis. In 2011, the City put \$40,000 into a Beach Safety program. The City spent \$23,000 for lifeguard positions in 2009. The Beach Patrol is there for code enforcement and public safety, not for rescuing. Tom Rotta commented that the City spends more and gets less service and makes the beach less attractive to tourism. He then referred to the concrete sidewalk adjacent to the transient dock. There are no guardrails and the lighting is poor. He referred to a visitor Ling Lan Zou, picture provided, whose body was recovered from the Marina. He connected two city deaths to leaving out guardrails and dropping the lifeguard program which according to Tom Rotta resulted in utter neglect of public safety. His final comment was that public safety is the responsibility of the local government.

Jerry Funk, Ludington Fire Department Fire Chief, commented that Tom Rotta continues to wear a Ludington Fire Department shirt and he is not a member of the Fire Department nor does he represent the Fire Department.

After no further comments were received, the regular order of business was resumed.

Moved by Councilor Johnson, seconded by Councilor Holman, to approve the minutes of the regular meeting 7/23/12. Motion Carried.

Moved by Councilor Taranko, seconded by Councilor Rathsack, that the Finance Report with total expenditures in the amount of \$582,269.23 for this period can be approved and orders drawn according to the City Charter. Motion Carried.

Moved by Councilor Taranko, seconded by Councilor Rathsack, to approve the Agreement for Professional Assessor Services. Motion Carried.

Councilor Castonia presented the Monthly Police Activity Report.

Councilor Holman presented the Monthly Building, Zoning and Enforcement Report.

RESOLUTION TO AMEND PART I, CHAPTER 3, SECTION 3.2
OF THE CITY CHARTER AND TO REPEAL ALL RESOLUTIONS
IN CONFLICT HEREWITH

BE IT RESOLVED, by the City Council of the City of Ludington, Michigan, as follows:

1. By initiatory petition, pursuant to the authority granted by Public Act 279 of 1909, as amended, it is proposed that Part I, Chapter 3, Section 3.2 of the Charter of the City of Ludington shall be amended to read as follows: Proposed Section 3.2. - The Mayor: The Mayor shall be the chief executive officer of the City and shall be nominated and elected by the voters of the City at large, for a term of four (4) years and shall serve no more than five (5) consecutive terms as Mayor. The Mayor shall be recognized as head of the city government for all ceremonial purposes and by the Governor for purposes of military law, but shall have no administrative duties except to make specific appointments as enumerated in Section 3.5 or other sections of this Charter. The Mayor shall preside at meetings of the Council, represent the City in intergovernmental relationships, appoint members of citizen advisory boards and commissions with the advice and consent of the Council, present an annual State of the City message, and perform other duties specified by the Council. The Mayor shall have an equal voice with all other members of the Council, but may vote only to break ties.
2. Provisions of existing Part I, Chapter 3, Section 3.2 of the Charter of the City of Ludington to be altered by such proposal, if adopted, now reads as follows: Existing Section 3.2. - The Mayor: The Mayor shall be the chief executive officer of the City and shall be nominated and elected by the voters of the City at large, for a term of four (4) years and shall serve no more than three (3) consecutive terms as Mayor. The Mayor shall be recognized as head of the city government for all ceremonial purposes and by the Governor for purposes of military law, but shall have no administrative duties except to make specific appointments as enumerated in Section 3.5 or other sections of this Charter. The Mayor shall preside at meetings of the Council, represent the City in intergovernmental relationships, appoint members of citizen advisory boards and commissions with the advice and consent of the Council, present an annual State of the City message, and perform other duties specified by the Council. The Mayor shall have an equal voice with all other members of the Council, but may vote only to break ties.
3. The City Clerk shall transmit a copy of the proposed amendment to the Governor of the State of Michigan for approval and transmit a copy of the ballot language for such proposed amendment to the Attorney General of the State of Michigan for approval as required by law.
4. The proposed amendment shall be submitted to the qualified electors of this City at the General Election to be held in the City of Ludington on the 6th day of November, 2012, and the City Clerk is directed to give notice of the election and notice of registration in the manner prescribed by law.
5. The proposed amendment shall be submitted to the electors in the following format:

PROPOSED AMENDMENT TO SECTION 3.2 OF THE CHARTER OF THE CITY OF LUDINGTON TO PERMIT THE MAYOR TO SERVE FIVE (5) 4-YEAR TERMS RATHER THAN THE CURRENT CHARTER PROVISION WHICH LIMITS THE NUMBER TO THREE (3) 4-YEAR TERMS.

This Charter Amendment is proposed for the purpose of increasing the maximum number of 4-year terms the Mayor may serve from three (3) terms to five (5) terms.

SHALL THE PROPOSED AMENDMENT TO PART I, CHAPTER 3, SECTION 3.2 BE ADOPTED?

YES

NO

6. The canvas and determination of the votes of said question shall be made in accordance with the laws of the State of Michigan and the Charter of the City of Ludington.

Councilor Holman presented the aforementioned resolution. The proposed amendment to the City Charter will permit the mayor to serve 5consecutive 4 year terms rather than the current City Charter provision which limits the mayor to serve for 3 consecutive 4 year terms. Councilor Holman admitted that she is a John Henderson fan and stated that he has a done a wonderful job for the City. Councilor Holman informed City Council that she received a certification of signatures from the City Clerk certifying that the signature requirement of 298 signatures has been met with a total of 308 qualifying signatures certified.

Moved by Councilor Holman, seconded by Councilor Castonia, that the City place the Proposed Charter Amendment to Part I, Chapter 3, Section 3.2 on the November 6, 2012 ballot.

Roll Call: Ayes: Councilors Holman, Rathsack, Taranko, Johnson, Marrison, Tykoski, and Castonia.
Nays: None. Motion Carried.

Councilor Castonia commented that he agreed with Councilor Holman, and we have a process to vote to not place a person in a position on the Council but we do not have a process to keep someone on Council. He also stated that Tom. Rotta criticized the Mayor for various things, but the Mayor did not have a vote on any of the items that he was criticized on. It was the City Council who votes on these items. Finally, Councilor Castonia expressed

appreciation to Heather Venzke-Tykoski for her efforts on the Community Garden. There have been seven harvests with the proceeds going to COVE and St. Simons Food Pantry.

Councilor Taranko read an article referring to the many honors placed on the many businesses in Ludington by the news media and many publications.

Councilor Holman referred to a comment made by Tom Rotta regarding the transient dock. She clarified that the Marina Fund is a separate fund and not part of the General Operating Fund.

Councilor Holman then referred to the two stacks of information that has been provided to Tom Rotta as a result of his FOIA requests. These stacks represent approximately \$6,500 in fees and there is a \$20 credit if you are indigent. There are approximately 150 hours included in this stack of paper. She stated that this is a fishing expedition and is done to harass the City. The City Attorney is on a retainer, we do have to go to the City Attorney with most of these FOIA request. Councilor Holman explained that she resents these requests, she will be here for two more years and she does not intend to stop talking about this. She stated that it is only fair to have Tom Rotta tell the City what he needs the information for.

Police Chief Barnett, referred to some statements that Tom Rotta commented on regarding the transient day dock. This dock is not constructed any differently than any other dock up and down coast in terms of access to the water. Every dock gives the same type of access to the water. Regarding the safety at the beach, Chief Barnett explained that about one month ago Officer Spencer Lindbloom, Seasonal Police Officer, used one of the life rings positioned on the north breakwater and threw it out to an individual who was drowning. He saved this individual. Yesterday one of the Beach Patrol Officers Matt Murphy began CPR on an individual on the beach. Chief Barnett stated that just because we do not have lifeguards does not mean we do not have safety coverage at the beach.

Councilor Castonia commented that the petunias are beautiful and thanked all involved in the care of these flowers. His Honor Mayor Henderson expressed appreciation to Tom Tyron for his care on these flowers.

His Honor Mayor Henderson addressed Tom Rotta on his comments regarding the lifeguards. He stated that the City must make value decisions when working on the budget. He explained that the City was not reducing the lifeguards but rather prioritizing the projects. The Beach Patrol informs people and educates people on rip tides and beach safety. The beach program is a top notch program with life rings and call centers. The City wants to educate people to swim within the designated swim area. He also stated that Tom Rotta made some poor assumptions in regards to the seasonal day dock.

His Honor Mayor Henderson publicly thanked Brandy Henderson, Heather Venzke-Tykoski, and Councilors Taranko and Castonia on their efforts for the Sunset Celebration.

Councilor Taranko commented that the decision to close the beach the other day was the right decision as there were no drownings at the Stearns Beach but there were drownings at other beaches.

Moved by Councilor Tykoski, seconded by Councilor Holman, that the meeting be adjourned. So carried at 7:17 p.m.



Deborah L. Luskin, CMC
City Clerk

"Resolution For Payment of Bills"

TO HIS HONOR THE MAYOR AND MEMBERS OF THE CITY COUNCIL

THE FOLLOWING ACCOUNTS HAVE BEEN EXAMINED BY YOUR FINANCE COMMITTEE AND PAYMENT IS HEREBY RECOMMENDED.

TOTAL ACCOUNTS PAYABLE FOR THIS PERIOD: \$ 774,540.07
TOTAL EXPENDITURES SINCE 08/13/2012, ARE \$ 172,348.14

THEREFORE THE FINANCE REPORT WITH TOTAL EXPENDITURES IN THE AMOUNT OF \$ 946,888.21
FOR THIS PERIOD CAN BE APPROVED AND ORDERS DRAWN ACCORDING TO THE
CITY CHARTER AND I SO MOVE.

INVOICE DISTRIBUTION REPORT FOR THE CITY OF LUDINGTON
 CHECKS DATED FROM 08/14/2012 - 08/27/2012
 GENERAL FUND

FOR THE CITY COUNCIL MEETING TO BE HELD ON AUGUST 27, 2012

Dept	Account	Payee	Description	Amount
000	002-100	CITY OF LUDINGTON	PAYROLL WEEK ENDING 08/11/2012	37,703.90
000	002-100	CITY OF LUDINGTON	PAYROLL WEEK ENDING 08/18/2012	30,428.18
265	853-000	FRONTIER	TELEPHONE	41.72
265	921-000	CONSUMERS ENERGY	UTILITIES - ELECTRIC	2,124.54
266	801-200	SNIEGOWSKI & BILALISIS PLC	PROFESSIONAL SERVICES - CRIMINAL	1,200.00
268	921-000	CONSUMERS ENERGY	UTILITIES - ELECTRIC	22.31
268	921-000	CONSUMERS ENERGY	UTILITIES - ELECTRIC	22.31
268	921-000	CONSUMERS ENERGY	UTILITIES - ELECTRIC	104.18
268	921-000	CONSUMERS ENERGY	UTILITIES - ELECTRIC	22.31
268	921-000	CONSUMERS ENERGY	UTILITIES - ELECTRIC	22.31
268	921-000	CONSUMERS ENERGY	UTILITIES - ELECTRIC	25.24
268	921-000	CONSUMERS ENERGY	UTILITIES - ELECTRIC	22.44
268	921-000	CONSUMERS ENERGY	UTILITIES - ELECTRIC	22.31
269	921-000	CONSUMERS ENERGY	UTILITIES - ELECTRIC	41.11
269	921-000	CONSUMERS ENERGY	UTILITIES - ELECTRIC	28.57
276	921-000	CONSUMERS ENERGY	UTILITIES - ELECTRIC	30.58
276	923-000	DTE ENERGY	UTILITIES - GAS	23.85
336	921-000	CONSUMERS ENERGY	UTILITIES - ELECTRIC	521.64
336	921-000	CONSUMERS ENERGY	UTILITIES - ELECTRIC	22.31
336	923-000	DTE ENERGY	UTILITIES - GAS	66.25
336	923-000	DTE ENERGY	UTILITIES - GAS	66.25
441	722-000	COMSTOCK, MICHAEL	CDL LICENSE REIMBURSEMENT	48.00
448	921-000	CONSUMERS ENERGY	UTILITIES - ELECTRIC	23.57
448	921-000	CONSUMERS ENERGY	UTILITIES - ELECTRIC	62.96
448	921-000	CONSUMERS ENERGY	UTILITIES - ELECTRIC	41.26
448	921-000	CONSUMERS ENERGY	UTILITIES - ELECTRIC	55.16
448	921-000	CONSUMERS ENERGY	UTILITIES - ELECTRIC	60.01
448	921-000	CONSUMERS ENERGY	UTILITIES - ELECTRIC	35.60
448	921-000	CONSUMERS ENERGY	UTILITIES - ELECTRIC	25.47
448	921-000	CONSUMERS ENERGY	UTILITIES - ELECTRIC	37.46
448	921-000	CONSUMERS ENERGY	UTILITIES - ELECTRIC	26.36
528	740-900	ALLIED WASTE SERVICES INC #239	YARD WASTE CONTAINERS PGS # 40	60.00
751	921-000	CONSUMERS ENERGY	UTILITIES - ELECTRIC	331.10
751	921-000	CONSUMERS ENERGY	UTILITIES - ELECTRIC	22.83
751	921-000	CONSUMERS ENERGY	UTILITIES - ELECTRIC	29.50
751	921-000	CONSUMERS ENERGY	UTILITIES - ELECTRIC	38.70
751	921-000	CONSUMERS ENERGY	UTILITIES - ELECTRIC	69.30
751	921-000	CONSUMERS ENERGY	UTILITIES - ELECTRIC	33.11
751	921-000	CONSUMERS ENERGY	UTILITIES - ELECTRIC	36.31
751	921-000	CONSUMERS ENERGY	UTILITIES - ELECTRIC	414.82
751	921-000	CONSUMERS ENERGY	UTILITIES - ELECTRIC	343.75
756	921-000	CONSUMERS ENERGY	UTILITIES - ELECTRIC	26.05
756	921-000	CONSUMERS ENERGY	UTILITIES - ELECTRIC	64.96
756	921-000	CONSUMERS ENERGY	UTILITIES - ELECTRIC	236.96
Total for fund 101 GENERAL FUND				74,663.24

FUND: 202 MAJOR STREETS FUND
 000 002-100 CITY OF LUDINGTON 1,946.02
 000 002-100 CITY OF LUDINGTON 2,658.61
 469 921-000 CONSUMERS ENERGY 28.31
 Total for fund 202 MAJOR STREETS FUND 4,632.94

FUND: 203 LOCAL STREETS FUND
 000 002-100 CITY OF LUDINGTON 959.55
 000 002-100 CITY OF LUDINGTON 556.77
 Total for fund 203 LOCAL STREETS FUND 1,516.32

FUND: 208 RECREATION FUND
 000 002-100 CITY OF LUDINGTON 2,036.60
 000 002-100 CITY OF LUDINGTON 1,897.64
 Total for fund 208 RECREATION FUND 3,934.24

FUND: 211 SENIOR CENTER FUND
 000 002-100 CITY OF LUDINGTON 2,205.05
 000 002-100 CITY OF LUDINGTON 2,205.07
 000 921-000 CONSUMERS ENERGY 607.78
 Total for fund 211 SENIOR CENTER FUND 5,017.90

FUND: 493 DDA OPERATING FUND
 000 002-100 CITY OF LUDINGTON 150.71
 000 002-100 CITY OF LUDINGTON 161.47
 000 004-000 ROGERS, LINDA J 100.00
 000 004-000 ROGERS, LINDA J 100.00
 Total for fund 493 DDA OPERATING FUND 512.18

FUND: 495 WATCHCASE CONTAMINATION FUND
 000 921-000 CONSUMERS ENERGY 301.73
 Total for fund 495 WATCHCASE CONTAMINATION FUND 301.73

FUND: 508 CARTIER PARK CAMPGROUND FUND
 000 002-100 CITY OF LUDINGTON 2,116.63
 000 002-100 CITY OF LUDINGTON 2,092.96
 Total for fund 508 CARTIER PARK CAMPGROUND FUND 4,209.59

FUND: 591 WATER MAINTENANCE & WATER FUND
 000 002-100 CITY OF LUDINGTON 11,291.31
 000 002-100 CITY OF LUDINGTON 11,629.36
 000 820-000 SAMUELS, NICHOLAS L 95.00
 000 921-000 CONSUMERS ENERGY 65.43
 556 921-000 CONSUMERS ENERGY 99.48
 Total for fund 591 WATER MAINTENANCE & WATER FUND 23,180.58

FUND: 592 SEWER MAINTENANCE & WASTEWATER FUND
 000 002-100 CITY OF LUDINGTON 7,250.23
 000 002-100 CITY OF LUDINGTON 7,707.76
 527 853-000 FRONTIER 52.50
 527 921-000 CONSUMERS ENERGY 124.03
 527 921-000 CONSUMERS ENERGY 3,073.13
 527 921-000 CONSUMERS ENERGY 36.92
 527 921-000 CONSUMERS ENERGY 30.34
 527 921-000 CONSUMERS ENERGY 326.89
 527 921-000 CONSUMERS ENERGY 54.31
 527 921-000 CONSUMERS ENERGY 781.81
 527 921-100 CONSUMERS ENERGY 13,540.88
 Total for fund 592 SEWER MAINTENANCE & WASTEWATER FUND 32,978.80

FUND: 594 MUNICIPAL MARINA FUND

Dept	Account	Payee	Description	Amount
000	002-100	CITY OF LUDINGTON	PAYROLL WEEK ENDING 08/11/2012	5,271.23
000	002-100	CITY OF LUDINGTON	PAYROLL WEEK ENDING 08/18/2012	4,989.11
000	921-000	CONSUMERS ENERGY	UTILITIES - ELECTRIC	139.70
000	921-000	CONSUMERS ENERGY	UTILITIES - ELECTRIC	28.83
000	923-000	DTE ENERGY	UTILITIES - GAS	122.42
Total for fund 594 MUNICIPAL MARINA FUND				10,551.29

Dept	Account	Payee	Description	Amount
FUND: 661 MOTOR POOL FUND				
000	002-100	CITY OF LUDINGTON	PAYROLL WEEK ENDING 08/11/2012	4,482.00
000	002-100	CITY OF LUDINGTON	PAYROLL WEEK ENDING 08/18/2012	4,738.42
000	921-000	CONSUMERS ENERGY	UTILITIES-ELECTRIC	1,562.53
000	930-000	CON-WAY FREIGHT INC	REPAIRS, MAINT. & SUPPLIES	66.38
Total for fund 661 MOTOR POOL FUND				10,849.33

GRAND TOTAL FOR ALL FUNDS: 172,348.14

INVOICE DISTRIBUTION REPORT FOR THE CITY OF LUDINGTON
 CHECKS DATED FROM 08/27/2012 TO 08/27/2012
 GENERAL FUND

FOR THE CITY COUNCIL MEETING TO BE HELD ON AUGUST 27, 2012

GL Number	Invoice Line Desc	Vendor	Invoice Description	Amount
Fund 101	GENERAL FUND			
Dept 000				
101-000-068-000	HEALTH INSURANCE - SEPTEMBER	PRIORITY HEALTH	HEALTH INSURANCE - SEPTEMBER	7,455.62
101-000-111-000	SUPPLY INVENTORY	EVERGREEN SOLUTIONS LLC	WIPES/TISSUE	558.60
101-000-239-200	DUE TO DELTA DENTAL	MICHIGAN RETAILERS ASSOCIATION	DENTAL INSURANCE	312.11
101-000-355-300	DEPOSITS	MOBERG, DIANE	RETURN SECURITY DEPOSIT	100.00
		Total For Dept 000		8,426.33
Dept 101	CITY COUNCIL & MAYOR			
101-101-853-000	TELEPHONE	RATHSACK, DICK	TELEPHONE REIMBURSEMENT	30.00
101-101-853-000	TELEPHONE	RATHSACK, DICK	TELEPHONE REIMBURSEMENT	30.00
101-101-860-000	TRANSPORTATION	TARANKO, WALTER	MAYOR'S EXCHANGE FRANKENMOUTH	180.93
101-101-956-000	MISCELLANEOUS EXPENSES	LUDINGTON & SCOTTVILLE CHAMBER	BUSINESS OUTING	90.00
		Total For Dept 101 CITY COUNCIL & MAYOR		330.93
Dept 172	MANAGER'S OFFICE			
101-172-719-000	HEALTH INSURANCE - SEPTEMBER	PRIORITY HEALTH	HEALTH INSURANCE - SEPTEMBER	1,079.70
101-172-727-000	OFFICE SUPPLIES	JACKPINE BUSINESS CENTER	FILE FOLDERS	14.39
101-172-956-000	MISCELLANEOUS EXPENSES	LUDINGTON & SCOTTVILLE CHAMBER	BUSINESS OUTING	90.00
		Total For Dept 172 MANAGER'S OFFICE		1,184.09
Dept 215	CLERK'S OFFICE			
101-215-719-000	HEALTH INSURANCE - SEPTEMBER	PRIORITY HEALTH	HEALTH INSURANCE - SEPTEMBER	2,156.55
101-215-727-000	OFFICE SUPPLIES	JACKPINE BUSINESS CENTER	LABELMAKER/LABELS/ENVELOPES	25.76
101-215-900-000	PRINTING & PUBLISHING	SHORELINE MEDIA INC	ADVERTISING	860.70
		Total For Dept 215 CLERK'S OFFICE		3,043.01
Dept 247	BOARD OF REVIEW			
101-247-900-000	PRINTING & PUBLISHING	SHORELINE MEDIA INC	ADVERTISING	90.60
		Total For Dept 247 BOARD OF REVIEW		90.60
Dept 253	TREASURER'S OFFICE			
101-253-719-000	HEALTH INSURANCE - SEPTEMBER	PRIORITY HEALTH	HEALTH INSURANCE - SEPTEMBER	939.70
101-253-727-000	OFFICE SUPPLIES	JACKPINE BUSINESS CENTER	LABELMAKER/LABELS/ENVELOPES	131.54
101-253-802-000	CONTRACTUAL SERVICES	KCI	POSTAGE - TAX BILLS	1,490.16
		Total For Dept 253 TREASURER'S OFFICE		2,561.40
Dept 257	ASSESSOR & BUILDING INSPECTOR'S OFFICE			
101-257-719-000	HEALTH INSURANCE - SEPTEMBER	PRIORITY HEALTH	HEALTH INSURANCE - SEPTEMBER	1,619.55
101-257-802-100	CONTRACTUAL SERVICES-BLDG I	BRITTON, EDWARD	BUILDING INSPECTIONS W/E 08/2012	518.32
		Total For Dept 257 ASSESSOR & BUILDING INSPECTOR'S OFFICE		2,137.87
Dept 262	ELECTIONS			
101-262-727-000	OFFICE SUPPLIES	PRINTING SYSTEMS INC	VOTER ID CARDS/MASTER CARDS	113.37
101-262-802-000	CONTRACTUAL SERVICES	EMANUEL LUTHERAN CHURCH	POLLING PLACE USE - 08/07/12	25.00

101-262-802-000 CONTRACTUAL SERVICES LAKESIDE CHURCH POLLING PLACE USE - 08/07/12 25.00

Total For Dept 262 ELECTIONS 163.37

Dept 265 CITY HALL & GROUNDS
 101-265-719-000 HEALTH INSURANCE - SEPTEMBER PRIORITY HEALTH HEALTH INSURANCE - SEPTEMBER 1,079.70
 101-265-923-000 UTILITIES - GAS DTE ENERGY GAS 49.72
 101-265-930-000 REPAIRS, MAINT. & SUPPLIES MODEL COVERALL SERVICE CLEAN MATS/RUNNERS 89.00
 Total For Dept 265 CITY HALL & GROUNDS 1,218.42

Dept 266 CITY ATTORNEY
 101-266-801-100 PROFESSIONAL SERVICES - CIVIL GOCKEMAN WILSON SAYLOR & HESSLIN RETAINER/SERVICES RENDERED - JULY 536.75
 101-266-801-100 PROFESSIONAL SERVICES - CIVIL GOCKEMAN WILSON SAYLOR & HESSLIN RETAINER/SERVICES RENDERED - JULY 4,000.00
 Total For Dept 266 CITY ATTORNEY 4,536.75

Dept 268 CITY PROPERTY-DOWNTOWN
 101-268-802-000 CONTRACTUAL SERVICES WEST MICHIGAN CMH SYSTEM CLEANING OF PUBLIC RESTROOMS 664.80
 Total For Dept 268 CITY PROPERTY-DOWNTOWN 664.80

Dept 276 CEMETERY
 101-276-719-000 HEALTH INSURANCE - SEPTEMBER PRIORITY HEALTH HEALTH INSURANCE - SEPTEMBER 1,079.70
 101-276-921-000 UTILITIES - ELECTRIC CONSUMERS ENERGY ELECTRIC 88.16
 101-276-930-000 REPAIRS, MAINT. & SUPPLIES LOWES BUSINESS ACCOUNT TOILET/BOLTS 239.87
 101-276-930-000 REPAIRS, MAINT. & SUPPLIES LOWES BUSINESS ACCOUNT TOILET BOLT CAPS/BOLTS (9.06)
 101-276-936-000 FOUNDATIONS LOWES BUSINESS ACCOUNT CEMENT BAGS/MARKING PAINT/SUBFLOOR 83.88
 Total For Dept 276 CEMETERY 1,482.55

Dept 301 POLICE DEPARTMENT
 101-301-719-000 HEALTH INSURANCE - SEPTEMBER PRIORITY HEALTH HEALTH INSURANCE - SEPTEMBER 9,357.38
 101-301-719-040 HEALTH INSURANCE - SEPTEMBER PRIORITY HEALTH HEALTH INSURANCE - SEPTEMBER 1,079.70
 Total For Dept 301 POLICE DEPARTMENT 10,437.08

Dept 302 SPECIAL POLICE
 101-302-719-000 HEALTH INSURANCE - SEPTEMBER PRIORITY HEALTH HEALTH INSURANCE - SEPTEMBER 1,079.70
 Total For Dept 302 SPECIAL POLICE 1,079.70

Dept 336 FIRE DEPARTMENT
 101-336-740-000 OPERATING SUPPLIES BRIGGS TRUE VALUE HARDWARE THERMOMETER 15.10
 101-336-740-000 OPERATING SUPPLIES BRIGGS TRUE VALUE HARDWARE STORAGE BOXES/LIGHTER/TAPE 23.24
 101-336-740-000 OPERATING SUPPLIES EVERGREEN SOLUTIONS LLC PLATES/NAPKINS/CUPS/PLASTIC WARE 62.50
 101-336-740-000 OPERATING SUPPLIES JACKPINE BUSINESS CENTER FOAM BOARD/CASH BOX 29.96
 101-336-860-000 TRANSPORTATION FUNK, GERALD MAYOR'S EXCHANGE FRANKENMUTH 183.15
 Total For Dept 336 FIRE DEPARTMENT 313.95

Dept 441 DPW/MUNICIPAL SERVICES
 101-441-719-000 HEALTH INSURANCE - SEPTEMBER PRIORITY HEALTH HEALTH INSURANCE - SEPTEMBER 8,633.07
 101-441-740-000 OPERATING SUPPLIES EVERGREEN SOLUTIONS LLC GLOVES 65.03
 101-441-740-000 OPERATING SUPPLIES EVERGREEN SOLUTIONS LLC DISINFECTANT 15.33
 101-441-740-000 OPERATING SUPPLIES FASTENAL COMPANY CABLE TIES 60.29
 101-441-740-000 OPERATING SUPPLIES FASTENAL COMPANY CABLE TIES 39.54
 101-441-740-000 OPERATING SUPPLIES NORTHERN SAFETY CO INC SAFETY GLASSES 226.60
 101-441-786-000 TRAFFIC CONTROL SUPPLIES LOWES BUSINESS ACCOUNT BOARDS/BITS/BRUSHES 81.44

101-441-802-000	CONTRACTUAL SERVICES	ALLIED WASTE SERVICES INC #239	REFUSE PICK UP - JULY / STICKERS	400.00
101-441-802-000	CONTRACTUAL SERVICES	SPULLER CONCRETE	REMOVE/REPLACE SIDEWALK @ 806 LOOMIS	156.25
101-441-802-000	CONTRACTUAL SERVICES	SPULLER CONCRETE	REMOVE/REPLACE SIDEWALK @ 710 LUDINGTON	467.50
101-441-802-000	CONTRACTUAL SERVICES	SPULLER CONCRETE	REMOVE/REPLACE SIDEWALK @ 201 FILER	2,011.25
101-441-900-000	PRINTING & PUBLISHING	SHORELINE MEDIA INC	ADVERTISING	75.50
101-441-956-000	MISCELLANEOUS	LUDINGTON & SCOTTVILLE CHAMBER	BUSINESS OUTFITTING	90.00
		Total For Dept 441 DPW/MUNICIPAL SERVICES		12,321.80

Dept 444 SIDEWALK CONSTRUCTION				
101-444-802-300	CONTRACTUAL SERVICES-SIDEWALK	SPULLER CONCRETE	REMOVE/REPLACE SIDEWALK @ 308 LOOMIS	739.50
101-444-802-300	CONTRACTUAL SERVICES-SIDEWALK	SPULLER CONCRETE	REMOVE/REPLACE SIDEWALK @ 721 E LOOMIS	921.25
101-444-802-300	CONTRACTUAL SERVICES-SIDEWALK	SPULLER CONCRETE	REMOVE/REPLACE SIDEWALK @ 201 FILER	305.00
		Total For Dept 444 SIDEWALK CONSTRUCTION		1,965.75

Dept 528 GARBAGE & RUBBISH				
101-528-740-900	ALLIED YARD WASTE SUPPLIES	ALLIED WASTE SERVICES INC #239	REFUSE PICK UP - JULY / STICKERS	576.00
101-528-802-000	CONTRACTUAL SERVICES	ALLIED WASTE SERVICES INC #239	REFUSE PICK UP - JULY / STICKERS	33,441.12
		Total For Dept 528 GARBAGE & RUBBISH		34,017.12

Dept 721 PLANNING COMMISSION/BOARD OF APPEALS				
101-721-900-000	PRINTING & PUBLISHING	SHORELINE MEDIA INC	ADVERTISING	196.30
		Total For Dept 721 PLANNING COMMISSION/BOARD OF APPEALS		196.30

Dept 728 ECONOMIC & COMMUNITY DEVELOPMENT				
101-728-719-000	HEALTH INSURANCE - SEPTEMBER	PRIORITY HEALTH	HEALTH INSURANCE - SEPTEMBER	899.74
101-728-727-000	OFFICE SUPPLIES	STAPLES CREDIT PLAN	ENGINEERING PRINTS/EASEL/PAPER	6.22
		Total For Dept 728 ECONOMIC & COMMUNITY DEVELOPMENT		905.96

Dept 751 PARKS DEPARTMENT				
101-751-719-000	HEALTH INSURANCE - SEPTEMBER	PRIORITY HEALTH	HEALTH INSURANCE - SEPTEMBER	1,079.70
101-751-740-000	OPERATING SUPPLIES	EVERGREEN SOLUTIONS LLC	DISINFECTANT/CLEANER/TOWELS	579.43
101-751-740-000	OPERATING SUPPLIES	EVERGREEN SOLUTIONS LLC	TOWELS/DISINFECTANT	414.60
101-751-802-000	CONTRACTUAL SERVICES	SPULLER CONCRETE	REMOVE/REPLACE SIDEWALK @ LOOMIS LAUNCH	500.00
101-751-802-000	CONTRACTUAL SERVICES	SPULLER CONCRETE	REMOVE/REPLACE SIDEWALK @ WATERFRONT PK	1,000.00
101-751-802-000	CONTRACTUAL SERVICES	SPULLER CONCRETE	REMOVE/REPLACE SIDEWALK @ WATERFRONT PK	1,710.00
101-751-802-000	CONTRACTUAL SERVICES	WEST MICHIGAN CMH SYSTEM	CLEANING OF PUBLIC RESTROOMS	664.80
101-751-930-000	REPAIRS, MAINT. & SUPPLIES	ALLEN R SHUFFLEBOARD CO INC	LARGE BALL RUNNERS	188.50
101-751-930-000	REPAIRS, MAINT. & SUPPLIES	LOWES BUSINESS ACCOUNT	TRIM PIECES/SWAGING TOOL/BIT TIP	70.68
101-751-930-000	REPAIRS, MAINT. & SUPPLIES	LUDINGTON LOCK & KEY	DISABLE TUMBLER	77.50
101-751-930-000	REPAIRS, MAINT. & SUPPLIES	STANDARD LUMBER & SUPPLY LLC	CEDAR SHINGLES	188.60
		Total For Dept 751 PARKS DEPARTMENT		6,473.81

Dept 753 BEACH SAFETY				
101-753-740-000	OPERATING SUPPLIES	FASTENAL COMPANY	CONNECTORS-BOUVIS	513.67
101-753-853-000	TELEPHONE	FRONTIER	TELEPHONE	50.19
		Total For Dept 753 BEACH SAFETY		563.86

Dept 756 LAUNCHING RAMPS				
101-756-802-000	CONTRACTUAL SERVICES	WEST MICHIGAN CMH SYSTEM	CLEANING OF PUBLIC RESTROOMS	1,329.60

GL Number	Invoice Line Desc	Vendor	Invoice Description	Amount
101-756-921-000	UTILITIES - ELECTRIC	CONSUMERS ENERGY	ELECTRIC	22.31
		Total For Dept 756 LAUNCHING RAMPS		1,351.91
		Total For Fund 101 GENERAL FUND		95,467.36

Fund 202 MAJOR STREETS FUND

Dept 451 CONSTRUCTION & SURFACING	ENGINEERING EXPENSES	FISHBECK THOMPSON CARR & HUBER INC	LUDINGTON/WASHINGTON BR TS&L	1,542.00
202-451-821-000	ENGINEERING EXPENSES	PREIN & NEMHOF, INC.	DOWLAND ST PROJECT	11,278.37
202-451-821-000	CAPITAL IMPROVEMENTS	HALLACK CONTRACTING INC	DOWLAND ST PROJECT	225,696.53
202-451-970-000		Total For Dept 451 CONSTRUCTION & SURFACING		238,516.90

Dept 464 SURFACE MAINTENANCE	ROAD MATERIALS & SUPPLIES	MASON COUNTY TRANSIT MIX	GRADER RINGS	79.50
202-464-782-000		Total For Dept 464 SURFACE MAINTENANCE		79.50

Fund 203 LOCAL STREETS FUND		Total For Fund 202 MAJOR STREETS FUND		238,596.40
-----------------------------	--	---------------------------------------	--	------------

Dept 451 CONSTRUCTION & SURFACING	CAPITAL IMPROVEMENTS	PREIN & NEMHOF, INC.	N GAYORD ST PROJECT	1,374.03
203-451-970-000		Total For Dept 451 CONSTRUCTION & SURFACING		1,374.03

Dept 464 SURFACE MAINTENANCE	ROAD MATERIAL & SUPPLIES	RIETH-RILEY CONSTRUCTION CO INC	COLD PATCH	152.95
203-464-782-000	ROAD MATERIAL & SUPPLIES	RIETH-RILEY CONSTRUCTION CO INC	COLD PATCH	146.30
		Total For Dept 464 SURFACE MAINTENANCE		299.25

Fund 208 RECREATION FUND		Total For Fund 203 LOCAL STREETS FUND		1,673.28
--------------------------	--	---------------------------------------	--	----------

Dept 000	JERSEYS/SHIRTS NON PAY PRGR	LUDINGTON MONKEY BUSINESS LLC	LIFEGUARD T-SHIRTS	33.00
208-000-744-000	REPAIRS, MAINT. & SUPPLIES	LUDINGTON PAINT & GLASS	GLOVES/PAINT	2.84
208-000-930-000	REPAIRS, MAINT. & SUPPLIES	LUDINGTON PAINT & GLASS	SPRAY PAINT	14.82
208-000-930-000	REPAIRS, MAINT. & SUPPLIES	LUDINGTON PAINT & GLASS	SPRAY PAINT/BRUSHES	88.78
		Total For Dept 000		139.44

Fund 211 SENIOR CENTER FUND		Total For Fund 208 RECREATION FUND		139.44
-----------------------------	--	------------------------------------	--	--------

Dept 000	HEALTH INSURANCE - SEPTEMBER	PRIORITY HEALTH	HEALTH INSURANCE - SEPTEMBER	1,299.59
211-000-719-000	OPERATING SUPPLIES	WAL-MART COMMUNITY	CORDLESS PHONE	14.88
211-000-740-000	UTILITIES - GAS	DTE ENERGY	GAS	126.00
211-000-923-000		Total For Dept 000		1,440.47

Total For Fund 211 SENIOR CENTER FUND				1,440.47
---------------------------------------	--	--	--	----------

Fund 215 WATERFRONT PLAYGROUND FUND
 Dept 000
 215-000-930-000 REPAIRS, MAINT & SUPPLIES SUPERIOR PLAY LLC BELT SEAT 408.94
 Total For Dept 000 408.94
 Total For Fund 215 WATERFRONT PLAYGROUND FUND 408.94

Fund 404 WEST LUDINGTON AVE IMPROVEMENT PROJ FUND
 Dept 000
 404-000-740-000 OPERATING SUPPLIES STAPLES CREDIT PLAN ENGINEERING PRINTS/EASEL/PAPER 94.92
 404-000-801-000 PROFESSIONAL SERVICES PROGRESSIVE AE WEST END LUDINGTON AVE 997.50
 Total For Dept 000 1,092.42
 Total For Fund 404 WEST LUDINGTON AVE IMPROVEMENT PROJ FUND 1,092.42

Fund 493 DDA OPERATING FUND
 Dept 000
 493-000-740-000 OPERATING SUPPLIES STAPLES CREDIT PLAN ENGINEERING PRINTS/EASEL/PAPER 6.22
 493-000-801-000 PROFESSIONAL SERVICES CNA SURETY ONE DAY LIQUOR LICENSE 50.00
 493-000-802-000 CONTRACTUAL SERVICES LASD GIRLS SWIM TEAM STAFFING INFLATABLES - FNL 300.00
 493-000-802-000 CONTRACTUAL SERVICES LASD HIGH SCHOOL RESOURCE CENTER STAFFING INFLATABLES - FNL 100.00
 493-000-853-000 TELEPHONE FRONTIER TELEPHONE 55.42
 493-000-921-000 UTILITIES - ELECTRIC CONSUMERS ENERGY ELECTRIC 72.04
 Total For Dept 000 583.68
 Total For Fund 493 DDA OPERATING FUND 583.68

Fund 495 WATCHCASE CONTAMINATION FUND
 Dept 000
 495-000-802-000 CONTRACTUAL SERVICES TRACE ANALYTICAL LABORATORIES TESTING 303.00
 495-000-927-000 UTILITIES - SEWER CITY OF LUDINGTON SEWER 2,548.86
 Total For Dept 000 2,851.86
 Total For Fund 495 WATCHCASE CONTAMINATION FUND 2,851.86

Fund 508 CARTIER PARK CAMPGROUND FUND
 Dept 000
 508-000-676-400 SITE RENTALS HEDDENS, WAYNE REFUND SITE PAYMENT 120.00
 508-000-676-400 SITE RENTALS VANDEUNTE, KARA REFUND PAYMENT DUE TO SITE CHANGE 5.00
 508-000-740-000 OPERATING SUPPLIES EVERGREEN SOLUTIONS LLC MATS 150.92
 508-000-740-000 OPERATING SUPPLIES EVERGREEN SOLUTIONS LLC SOAP/TISSUE/TOWELS 186.34
 508-000-740-300 VENDING SUPPLIES LUDINGTON OUTDOOR SERVICES WOOD BUNDLES 933.75
 508-000-921-000 UTILITIES - ELECTRIC CONSUMERS ENERGY ELECTRIC 3,256.66
 508-000-921-000 UTILITIES - ELECTRIC CONSUMERS ENERGY ELECTRIC 60.32
 508-000-930-000 REPAIR, MAINTENANCE, SUPPLIES BRIGGS TRUE VALUE HARDWARE BACK FLOW PREVENTER 29.81
 508-000-930-000 REPAIR, MAINTENANCE, SUPPLIES LUDINGTON PAINT & GLASS PAINT 56.00
 Total For Dept 000 4,798.80
 Total For Fund 508 CARTIER PARK CAMPGROUND FUND 4,798.80

GI Number	Invoice Line Desc	Vendor	Invoice Description	Amount
Fund 591 WATER MAINTENANCE & WATER FUND				
Dept 000				
591-000-719-000	HEALTH INSURANCE - SEPTEMBER	PRIORITY HEALTH	HEALTH INSURANCE - SEPTEMBER	3,509.01
591-000-740-000	OPERATING SUPPLIES	AMERICAN WATER WORKS ASSOCIATION	HYDRANTS MANUAL	78.32
591-000-740-000	OPERATING SUPPLIES	EVERGREEN SOLUTIONS LLC	SCRUBS IN A BUCKET	13.58
591-000-740-000	OPERATING SUPPLIES	EVERGREEN SOLUTIONS LLC	TOWELS/WIPES	65.77
591-000-782-000	ROAD MATERIAL & SUPPLIES	GREAT LAKES MATERIALS INC	TRAP ROCK	217.64
591-000-802-000	CONTRACTUAL SERVICES	HALLACK CONTRACTING INC	EQUIPMENT - DELTA/HAIGHT	860.00
591-000-930-000	REPAIRS, MAINT. & SUPPLIES	ETNA SUPPLY COMPANY	CURB STOPS	458.56
591-000-930-000	REPAIRS, MAINT. & SUPPLIES	POLLARDWATER.COM - EAST	HANDLES	1,062.58
591-000-970-801	CAPITAL IMPROVEMENT-PROF	PREIN & NEWHOF, INC.	DOWLAND ST PROJECT	4,887.30
591-000-970-802	CAPITAL IMPROVEMENT-CONTR	HALLACK CONTRACTING INC	DOWLAND STREET PROJECT	97,801.83
591-000-982-000	METERS & HYDRANTS	ETNA SUPPLY COMPANY	METER/FITTINGS	890.00
		Total For Dept 000		109,844.59

Dept 556 WATER FUND				
591-556-719-000	HEALTH INSURANCE - SEPTEMBER	PRIORITY HEALTH	HEALTH INSURANCE - SEPTEMBER	7,377.94
591-556-740-000	OPERATING SUPPLIES	ARGUS HAZCO	CALIBRATION / FILTERS	148.41
591-556-740-000	OPERATING SUPPLIES	ENVIRONMENTAL RESOURCE ASSOC	LAB SUPPLIES	266.18
591-556-740-000	OPERATING SUPPLIES	JACKRINE BUSINESS CENTER	INK CARTRIDGE	14.99
591-556-740-000	OPERATING SUPPLIES	MEDLER ELECTRIC COMPANY	REPLACEMENT TIMER	60.00
591-556-740-000	OPERATING SUPPLIES	PITNEY BOWES	MAIL WATER / SEWER BILLS	133.50
591-556-740-000	OPERATING SUPPLIES	PRINTING SYSTEMS INC	WATER/SEWER BILLS	589.59
591-556-740-000	OPERATING SUPPLIES	RADIO SHACK CORPORATION	BATTERIES	57.46
591-556-740-000	OPERATING SUPPLIES	RITE AID STORE #04567	LAB SUPPLIES	144.24
591-556-801-000	PROFESSIONAL SERVICE	FISBECK THOMPSON CARR & HUBER INC	LUDINGTON/REL STUDY GEN PLAN	447.00
591-556-802-000	CONTRACTUAL SERVICES	AMERICAN MESSAGING	PAGING SERVICE	7.64
591-556-853-000	TELEPHONE	MALZAHN, KURT	TELEPHONE REIMBURSEMENT	30.00
591-556-921-000	UTILITIES - ELECTRIC	CONSUMERS ENERGY	ELECTRIC	544.65
591-556-921-000	UTILITIES - ELECTRIC	CONSUMERS ENERGY	ELECTRIC	49.22
591-556-921-000	UTILITIES - ELECTRIC	CONSUMERS ENERGY	ELECTRIC	53.08
591-556-930-000	REPAIRS, MAINT. & SUPPLIES	GREAT LAKES ENERGY	ELECTRIC	31.03
591-556-930-000	REPAIRS, MAINT. & SUPPLIES	HOME DEPOT CREDIT SERVICES	BOARDS	137.84
591-556-930-000	REPAIRS, MAINT. & SUPPLIES	MEDLER ELECTRIC COMPANY	CONDUIT	9.45
591-556-930-000	REPAIRS, MAINT. & SUPPLIES	MEDLER ELECTRIC COMPANY	CONDUIT	17.70
591-556-930-000	REPAIRS, MAINT. & SUPPLIES	MEDLER ELECTRIC COMPANY	CONNECTORS	4.28
591-556-930-000	REPAIRS, MAINT. & SUPPLIES	MEDLER ELECTRIC COMPANY	CONNECTORS	21.38
591-556-930-000	REPAIRS, MAINT. & SUPPLIES	MEDLER ELECTRIC COMPANY	RIGID CONDUITS	37.32
591-556-930-000	REPAIRS, MAINT. & SUPPLIES	MEDLER ELECTRIC COMPANY	BIT STEP	74.97
591-556-930-000	REPAIRS, MAINT. & SUPPLIES	MEDLER ELECTRIC COMPANY	BATTERY	12.34
591-556-930-000	REPAIRS, MAINT. & SUPPLIES	MEDLER ELECTRIC COMPANY	RIGID CONDUIT	14.13
591-556-930-000	REPAIRS, MAINT. & SUPPLIES	MEDLER ELECTRIC COMPANY	SPRING NUT	42.95
591-556-930-000	REPAIRS, MAINT. & SUPPLIES	MEDLER ELECTRIC COMPANY	CONNECTORS	28.04
591-556-930-000	REPAIRS, MAINT. & SUPPLIES	MEDLER ELECTRIC COMPANY	FLEX CONNECTORS/CABLE TIE MOUNT	128.20
		Total For Dept 556 WATER FUND		10,483.53
		Total For Fund 591 WATER MAINTENANCE & WATER FUND		120,328.12

Fund 592 SEWER MAINTENANCE & WASTEWATER FUND				
Dept 000				
592-000-719-000	HEALTH INSURANCE - SEPTEMBER	PRIORITY HEALTH	HEALTH INSURANCE - SEPTEMBER	1,529.57

592-000-740-000	OPERATING SUPPLIES	EVERGREEN SOLUTIONS LLC	SCRUBS IN A BUCKET	13.58
592-000-740-000	OPERATING SUPPLIES	EVERGREEN SOLUTIONS LLC	TOWELS/WIPES	65.77
592-000-970-801	CAPITAL IMPROVEMENT-PROF	PREIN & NEWHOF, INC.	DOWLAND ST PROJECT	2,631.62
592-000-970-802	CAPITAL IMPROVEMENT-CONT	HALLACK CONTRACTING INC	DOWLAND STREET PROJECT	52,662.53
		Total For Dept 000		56,903.07

Dept 527 WASTEWATER FUND				
592-527-719-000	HEALTH INSURANCE - SEPTEMBER	PRIORITY HEALTH	HEALTH INSURANCE - SEPTEMBER	2,379.29
592-527-740-000	OPERATING SUPPLIES	EVERGREEN SOLUTIONS LLC	GLOVES	67.50
592-527-740-000	OPERATING SUPPLIES	HACH COMPANY	IODINE	54.75
592-527-740-000	OPERATING SUPPLIES	HACH COMPANY	IODINE	397.90
592-527-740-000	OPERATING SUPPLIES	IUDINGTON PLUMBING CORP	FLOOR FLANGE/PIPE	88.06
592-527-740-000	OPERATING SUPPLIES	NORTH CENTRAL LABORATORIES	TUBES/BRUSH/BUFFER SOLUTION	519.96
592-527-740-000	OPERATING SUPPLIES	PITNEY BOWES	MAIL WATER / SEWER BILLS	133.50
592-527-740-000	OPERATING SUPPLIES	PRINTING SYSTEMS INC	WATER/SEWER BILLS	589.59
592-527-740-000	OPERATING SUPPLIES	SHOP-N-SAVE FOOD CENTER	PAPER/CLEANING PRODUCTS	96.24
592-527-740-000	OPERATING SUPPLIES	TIRE IT WHOLESALE	TIRE TUBE	15.65
592-527-802-000	CONTRACTUAL SERVICES	WEBB CHEMICAL SERVICE CORP.	CHLORIDE SOLUTION	4,479.93
592-527-802-000	CONTRACTUAL SERVICES	CAI ELECTRIC INC	REPAIR BLOWER	147.00
592-527-802-000	CONTRACTUAL SERVICES	METTLER - TOLEDO INC	SERVICE SCALES	293.50
592-527-802-000	CONTRACTUAL SERVICES	W W WILLIAMS	WORK ON GENERATOR	1,036.00
592-527-802-000	CONTRACTUAL SERVICES	W W WILLIAMS	WORK ON GENERATOR	2,253.27
592-527-921-000	UTILITIES - ELECTRIC	CONSUMERS ENERGY	ELECTRIC	122.89
592-527-923-000	UTILITIES - GAS	DTE ENERGY	GAS	52.98
592-527-923-100	GAS - WWTTP	DTE ENERGY	GAS	210.00
592-527-991-100	07 BOND: PRINCIPAL	THE BANK OF NEW YORK TRUST COMPANY	PRINCIPAL / INTEREST	70,000.00
592-527-995-100	96 BOND: INTEREST	THE BANK OF NEW YORK TRUST COMPANY	PRINCIPAL / INTEREST	10,075.00
		Total For Dept 527 WASTEWATER FUND		93,013.01

Total For Fund 592 SEWER MAINTENANCE & WASTEWATER FUND 149,916.08

Fund 594 MUNICIPAL MARINA FUND				
Dept 000	HEALTH INSURANCE - SEPTEMBER	PRIORITY HEALTH	HEALTH INSURANCE - SEPTEMBER	1,079.70
594-000-719-000	OPERATING SUPPLIES	ALLARD'S ECOWATER SYSTEMS	WATER BOTTLE/RETURNS	65.00
594-000-740-000	OPERATING SUPPLIES	JACKRINE BUSINESS CENTER	INKJET CARTRIDGES/BUSINESS CARDS	47.93
594-000-740-000	OPERATING SUPPLIES	SHOP-N-SAVE FOOD CENTER	COFFEE	20.93
594-000-740-100	ICE	ALLIN ICE COMPANY	BAGS OF ICE	125.00
594-000-740-100	ICE	ALLIN ICE COMPANY	BAGS OF ICE	125.00
594-000-740-100	ICE	THE ICE BOX COMPANY INC	ICE BAGS	95.57
594-000-740-200	POP	PEPSI-COLA	PEPSI PRODUCTS	92.40
594-000-740-200	POP	PEPSI-COLA	PEPSI PRODUCTS	12.00
594-000-744-000	CLOTHING ALLOWANCE	CUTTING EDGE IMAGE & DESIGN LLC	SHIRTS - MARINA TOURNAMENT	250.00
594-000-751-000	GASOLINE	BRENNER OIL COMPANY	GASOLINE PURCHASED	9,009.44
594-000-751-000	GASOLINE	BRENNER OIL COMPANY	GASOLINE PURCHASED	13,460.79
594-000-751-000	GASOLINE	BRENNER OIL COMPANY	GASOLINE PURCHASED	10,029.10
594-000-751-000	GASOLINE	BRENNER OIL COMPANY	GASOLINE PURCHASED	10,718.89
594-000-751-000	GASOLINE	BRENNER OIL COMPANY	GASOLINE PURCHASED	6,894.22
594-000-751-000	GASOLINE	BRENNER OIL COMPANY	GASOLINE PURCHASED	13,506.69
594-000-751-000	GASOLINE	BRENNER OIL COMPANY	GASOLINE PURCHASED	9,112.84
594-000-751-100	DIESEL	BRENNER OIL COMPANY	DIESEL PURCHASED	2,260.41

594-000-751-100	DIESEL	BRENNER OIL COMPANY	DIESEL PURCHASED	3,047.63
594-000-751-100	DIESEL	BRENNER OIL COMPANY	DIESEL PURCHASED	6,166.20
594-000-751-100	DIESEL	BRENNER OIL COMPANY	DIESEL PURCHASED	2,590.12
594-000-751-100	DIESEL	BRENNER OIL COMPANY	DIESEL PURCHASED	1,977.06
594-000-751-100	DIESEL	BRENNER OIL COMPANY	DIESEL PURCHASED	1,797.75
594-000-751-100	DIESEL	BRENNER OIL COMPANY	DIESEL PURCHASED	2,859.54
594-000-802-000	CONTRACTED SERVICES	PORTSIDE FLORAL	RESTROOM ARRANGEMENTS	55.25
594-000-802-000	CONTRACTED SERVICES	PORTSIDE FLORAL	RESTROOM ARRANGEMENTS	54.50
594-000-802-000	CONTRACTED SERVICES	PORTSIDE FLORAL	RESTROOM ARRANGEMENTS	62.50
594-000-900-000	PRINTING & PUBLISHING	SHORELINE MEDIA INC	ADVERTISING	31.35
594-000-930-000	REPAIRS, MAINT. & SUPPLIES	EVERGREEN SOLUTIONS LLC	CAN LINERS/GLOVES/SOAP	298.33
594-000-930-000	REPAIRS, MAINT. & SUPPLIES	EVERGREEN SOLUTIONS LLC	CLEANER/TOWELS/TISSUE	192.83
594-000-930-000	REPAIRS, MAINT. & SUPPLIES	EVERGREEN SOLUTIONS LLC	TOWELS/TISSUE/HANDSOAP/CLEANER	250.45
594-000-930-000	REPAIRS, MAINT. & SUPPLIES	EVERGREEN SOLUTIONS LLC	MOP/HANDSOAP/OIL PADS	228.65
594-000-956-000	MISCELLANEOUS EXPENSES	LUDINGTON & SCOTTVILLE CHAMBER	BUSINESS OUTFING	90.00
Total For Dept 000				96,608.07
Total For Fund 594 MUNICIPAL MARINA FUND				96,608.07

Fund 650 TECHNOLOGY FUND				
Dept 000	CONTRACTUAL SERVICES	REVIZE LLC	WEB HOSTING	2,400.00
650-000-802-000	CONTRACTUAL SERVICES	TERRAPIN NETWORKS	ONSITE VISITS	100.00
650-000-802-000	CONTRACTUAL SERVICES	TERRAPIN NETWORKS	IT SUPPORT - SEPTEMBER	2,746.00
650-000-802-100	INTERNET CONNECTIONS	MICHAWE INTERNET SERVICES	INTERNET SERVICE	70.00
Total For Dept 000				5,316.00
Total For Fund 650 TECHNOLOGY FUND				5,316.00

Fund 661 MOTOR POOL FUND				
Dept 000	HEALTH INSURANCE - SEPTEMBER	PRIORITY HEALTH	HEALTH INSURANCE - SEPTEMBER	3,419.05
661-000-719-000	HEALTH INSURANCE - SEPTEMBER	PRIORITY HEALTH	HEALTH INSURANCE - SEPTEMBER	3,419.05
661-000-740-000	OPERATING SUPPLIES	BEAVER RESEARCH COMPANY	RUBBER WORKS/RUST PROTECTOR	779.13
661-000-743-000	TOOLS	H & R INDUSTRIES INC	VEHICLE WASH	93.50
661-000-751-000	GASOLINE, MOTOR OIL, ETC.	TRACTOR SUPPLY CO.	SCREWDRIVER/WRENCH SET	89.98
661-000-751-000	GASOLINE, MOTOR OIL, ETC.	SCOTLAND OIL COMPANY INC	DIESEL PURCHASED	25,358.03
661-000-923-000	UTILITIES - GAS	SCOTLAND OIL COMPANY INC	GASOLINE PURCHASED	18,081.25
661-000-930-000	REPAIRS, MAINT. & SUPPLIES	DTE ENERGY	GAS	71.81
661-000-930-000	REPAIRS, MAINT. & SUPPLIES	BELL EQUIPMENT COMPANY INC	DIRT SHOE ASSEMBLIES	844.28
661-000-930-000	REPAIRS, MAINT. & SUPPLIES	FREEMAN CREEK EQUIPMENT INC	POST HOLE DRIVER/MOUNTING BRACKET	3,134.00
661-000-930-000	REPAIRS, MAINT. & SUPPLIES	FREEMAN CREEK EQUIPMENT INC	HOSE END	10.13
661-000-930-000	REPAIRS, MAINT. & SUPPLIES	GRAINGER	TANK SPRAYER	62.90
661-000-930-000	REPAIRS, MAINT. & SUPPLIES	KENT RUBBER SUPPLY INC	CONNECTIONS/SWIVEL	21.01
661-000-930-000	REPAIRS, MAINT. & SUPPLIES	LUDINGTON PLUMBING CORP	CAMLOCK GASKET	17.30
661-000-930-000	REPAIRS, MAINT. & SUPPLIES	MCMASTER-CARR SUPPLY CO	SEALED STEEL RING/ROLLER CHAIN	291.58
661-000-930-000	REPAIRS, MAINT. & SUPPLIES	MEDLER ELECTRIC COMPANY	SPEED LINK/LAMP/TANDEM BAY LIGHTS	1,853.90
661-000-930-000	REPAIRS, MAINT. & SUPPLIES	MODEL COVERALL SERVICE	CLEAN MATS/RUNNERS	48.61
661-000-930-000	REPAIRS, MAINT. & SUPPLIES	SPARVAN DISTRIBUTORS INC	SPRING ROD IDLER/TENSION/CAPSCREW	20.84
661-000-930-000	REPAIRS, MAINT. & SUPPLIES	SPARVAN DISTRIBUTORS INC	IDLER SPROCKET ASSEMBLIES/REELS CHAINS	707.10
661-000-930-000	REPAIRS, MAINT. & SUPPLIES	SPARVAN DISTRIBUTORS INC	SPRING ROD IDLER	44.28
661-000-930-000	REPAIRS, MAINT. & SUPPLIES	TERMINAL SUPPLY INC	CAP SCREW/BRIDGE PIN CLIP	52.29

GL Number	Invoice Line Desc	Vendor	Invoice Description	Amount
661-000-930-000	REPAIRS, MAINT. & SUPPLIES	TIRE IT WHOLESAL	MOWER TIRE	75.00
661-000-930-000	REPAIRS, MAINT. & SUPPLIES	WEST MICHIGAN INTERNATIONAL LLC	BOLTS	21.48
661-000-930-000	REPAIRS, MAINT. & SUPPLIES	WEST MICHIGAN INTERNATIONAL LLC	SWITCH	(21.24)
661-000-930-000	REPAIRS, MAINT. & SUPPLIES	WEST MICHIGAN INTERNATIONAL LLC	OIL LINE	66.95
661-000-930-000	REPAIRS, MAINT. & SUPPLIES	WINDER POLICE EQUIPMENT INC	LED LIGHT BAR	175.99
		Total For Dept 000		55,319.15
		Total For Fund 661 MOTOR POOL FUND		55,319.15

TOTAL FOR ALL FUNDS: 774,540.07

TOTAL FOR ACCOUNTS PAYABLE:

Fund 101 GENERAL FUND	95,467.36
Fund 202 MAJOR STREETS FUND	238,596.40
Fund 203 LOCAL STREETS FUND	1,673.28
Fund 208 RECREATION FUND	139.44
Fund 211 SENIOR CENTER FUND	1,440.47
Fund 215 WATERFRONT PLAYGROUND FUND	408.94
Fund 404 WEST LUDINGTON AVE IMPROVEMENT PROJ	1,092.42
Fund 493 DDA OPERATING FUND	583.68
Fund 495 WATCHCASE CONTAMINATION FUND	2,851.86
Fund 508 CARTIER PARK CAMPGROUND FUND	4,798.80
Fund 591 WATER MAINTENANCE & WATER FUND	120,328.12
Fund 592 SEWER MAINTENANCE & WASTEWATER FUND	149,916.08
Fund 594 MUNICIPAL MARINA FUND	96,608.07
Fund 650 TECHNOLOGY FUND	5,316.00
Fund 661 MOTOR POOL FUND	55,319.15

TOTAL FOR ALL FUNDS: 774,540.07

Summary

PREPAID EXPENDITURES

All Funds	\$	172,348.14		
Building Rehab Fund 422	\$	-		
Building Authority Fund 371	\$	-		
Police Pension Fund 732	\$	-		
Tax Distributions	(2937)	\$	38.13	
TOTAL EXPENDITURES SINCE 08/13/2012:		\$		172,386.27
LESS TAX DIST., TRANSFERS & CD PURCHASES:		\$	38.13	
TOTAL PREPAID EXPENDITURES SINCE 08/13/2012:		\$		172,348.14

ACCOUNTS PAYABLE

ALL FUNDS:	\$	774,540.07		
TOTAL ACCOUNTS PAYABLE FOR THIS PERIOD:		\$	774,540.07	
TOTAL PREPAID EXPENDITURES:		\$	172,348.14	
TOTAL EXPENDITURES SINCE 08/13/2012:		\$	946,888.21	



Deborah L. Luskin, City Clerk

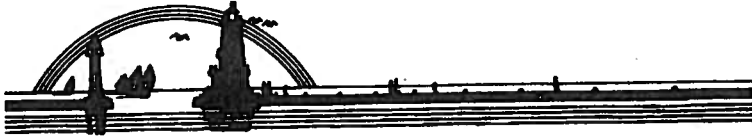

JOHN HENDERSON, MAYOR
JOHN E. SHAY, CITY MANAGER
DEBORAH L. LUSKIN, CITY CLERK
LINDA J. ROGERS, CITY TREASURER

CITY OF LUDINGTON

400 SOUTH HARRISON STREET
LUDINGTON, MICHIGAN 49431
PHONE (231) 845-6237
FAX (231) 845-1146

MEMORANDUM

TO: Mayor Henderson and the Ludington City Council
FROM: John Shay, City Manager JS
DATE: August 24, 2012
RE: Tom Rotta's Appeal of FOIA Decision

I have attached a FOIA request from Tom Rotta dated August 14, 2012 in which he requested to inspect "the two large stacks of papers that were at Kaye Holman's right at the 8-13-2012 City Council Meeting which were alleged to be 90% of the FOIA requests I had made to the City of Ludington. It is my understanding that since these public records were compiled for Councilor Holman's lecture, the perusal of these prepared documents should not cost anything to view..."

The City granted the request in part and denied the request in part. Mr. Rotta's understanding that these records were compiled specifically for City Councilor Holman is wrong. These records represent most or all of the FOIA requests that Mr. Rotta has requested over the past 3-4 years and were compiled during that time period. Some of these records he has already received and some of the records he has not received either because they are exempt from disclosure or because he refused to reimburse the City for the costs to compile these records. Therefore, I informed Mr. Rotta that the City's previous responses to his previous FOIA requests still stand. Mr. Rotta has appealed this decision.

CITY MANAGER'S RECOMMENDATION: Affirm the FOIA Coordinator's response dated August 22, 2012 to Mr. Rotta's FOIA request dated August 14, 2012.

On the Shores of Lake Michigan

John Shay

From: John Shay
Sent: Wednesday, August 22, 2012 12:50 PM
To: 'Tom Rotta'
Subject: RE: FOIA Request: Kay Holman's two stacks
Attachments: Response to Rotta's FOIA Request 8-14-12.pdf

Tom:

The records that you are requesting in your FOIA request were not compiled for City Councilor Kaye Holman's presentation at the City Council meeting on August 13, 2012. These records represent most of the records that you have requested in previous FOIA requests. Some of these records you have already received and some you have not either because the records are exempt from disclosure or because you did not reimburse the City for the fees that the City charged to compile these records. Therefore, the City's previous responses to your previous FOIA requests still stand, as noted in the attached FOIA response dated August 22, 2012.

John Shay
City Manager
City of Ludington
400 South Harrison Street
Ludington, Michigan 49431
(231) 845-6237 Voice
(231) 845-7302 Fax
ishay@ci.ludington.mi.us

From: Tom Rotta [<mailto:tomrotta@rocketmail.com>]
Sent: Tuesday, August 14, 2012 4:19 PM
To: John Shay
Subject: FOIA Request: Kay Holman's two stacks

John,

Under provisions of the Michigan Freedom of Information Act (MCLA 15.231 et seq; MSA 4.1801 (1) et seq) I am requesting to personally inspect the following public records :

The two large stacks of papers that were at Kaye Holman's right at the 8-13-2012 City Council Meeting which were alleged to be 90% of the FOIA requests I had made to the City of Ludington. It is my understanding that since these public records were compiled for Councilor Holman's lecture, the perusal of these prepared documents should not cost anything to view, with my intention of making copies of them-- the ones that have been withheld from me due to unlawfully being priced-out of viewing them. If you still irrationally believe I owe you something for them, be sure to keep that stack at hand, because I will have someone else, other than me or Toni, to do a separate FOIA request on those two stacks. Remember, we just wish to **inspect** these already FOIA-prepared documents.

If you need any clarifications of this request, please reply expediently to this E-mail address.

If requested record(s) do not exist, please enumerate which ones do not, as per the Act.

If you determine that some of the requested information is exempt from disclosure, please detail what is being withheld and cite the exemption under FOIA.

If fees to comply with this request exceed \$20, please contact me at this E-Mail address with those fees enumerated.

As provided under FOIA, I would anticipate my request being filled within five working days of receipt of this letter.

Tom Rotta

The Ludington Torch

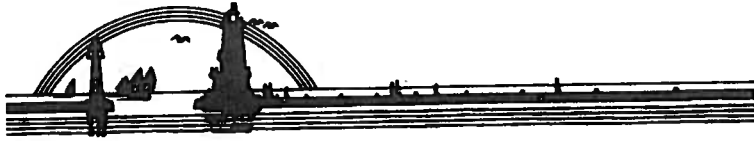

JOHN HENDERSON, MAYOR
JOHN E. SHAY, CITY MANAGER
DEBORAH L. LUSKIN, CITY CLERK
LINDA J. ROGERS, CITY TREASURER

CITY OF LUDINGTON

400 SOUTH HARRISON STREET
LUDINGTON, MICHIGAN 49431
PHONE (231) 845-6237
FAX (231) 845-1146

August 22, 2012

Mr. Tom Rotta
137 East Dowland Street
Ludington, Michigan 49431

RE: Response to Freedom of Information Act ("FOIA") Request Received Via E-Mail on August 15, 2012

Dear Mr. Rotta:

Your recent request for public record(s) under the Michigan Freedom of Information Act ("FOIA"), MCL §15.231 et seq, as amended, is hereby:

- Granted, requested record(s) available. Please remit \$0.00 to cover costs (see e-mail).
- Granted, however the cost of responding to your request is estimated to exceed \$50.00, therefore a deposit of \$_____ (1/2 estimated cost) will be required. Upon receipt of your deposit, the City will compile the requested record(s).
- Granted, your name will be placed on a subscription list for future issuances of the requested record(s) disseminated on a regular basis. This subscription shall be valid for six (6) months and shall be renewable only upon written request each six (6) months.
- Denied, requested records(s) exempt from disclosure for the following reason(s):
 - A public record does not exist under the name given or by another name reasonably known by the FOIA Coordinator.
 - Requested record(s) are of a personal nature and the disclosure of the information would constitute a clearly unwarranted invasion of an individual's privacy.
 - Requested records are investigative records compiled for law enforcement purposes and disclosure would interfere with law enforcement proceedings, deprive a person of the right to a fair trial or impartial administrative adjudication, constitute an unwarranted invasion of personal privacy or disclose the identity of a confidential source or disclose confidential information furnished by a confidential source.
 - Records or information specifically described and exempted from disclosure by statute.

On the Shores of Lake Michigan

- Requested record(s) would prevent the body from complying with Section 444 of subpart 4 of part C of the General Education Provisions Act, 20 USC 1232g.
- Requested record(s) are trade secrets or commercial or financial information voluntarily provided to an agency for developing governmental policy.
- Requested record(s) are subject to the attorney-client privilege.
- Requested record(s) are subject to the physician-patient, psychologist-patient, minister, priest, or Christian Science practitioner privilege, or other privilege recognized by statute or court rule.
- Requested record(s) are a bid or proposal to enter into a contract or agreement prior to the time established for submission or public opening.
- Requested record(s) are appraisals of real property to be acquired prior to an agreement for purchase, or less than three (3) years after the appraisal date.
- Requested record(s) are medical, counseling, or psychological facts or evaluations which would disclose an individual's identity.
- Requested record(s) are communications and notes within a public body or between public bodies of an advisory nature to the extent that they cover other than purely factual materials and are preliminary to a final determination of policy or action.
- Requested record(s) are law enforcement communication codes, or plans for deployment that if disclosed would prejudice the public body's ability to protect the public safety and the public interest in disclosure does not outweigh the public interest in nondisclosure in this particular instance.
- Requested record(s) are testing data for determining whether bidder's products meet specifications.
- Requested records are public records of a law enforcement agency, the release of which would do any of the following: (i) identify or provide a means of identifying an informant; (ii) identify or provide means to identify an undercover officer, agent or plain clothes officer; (iii) disclose the personal address or telephone number of active or retired law enforcement personnel or a special skill they may have; (iv) disclose the name, address or phone number of family members, relatives, children or parents of active or retired law enforcement personnel; (v) disclose operational instructions; (vi) reveal the contents of staff manuals provided to law enforcement personnel; (vii) endanger the life or safety of law enforcement personnel or their family members or those who furnish information to law enforcement agencies; (viii) identify or provide means of identifying a person as a law enforcement officer, agent or informant; (ix) disclose personnel records; or (x) identify or provide means to identifying residences that law enforcement personnel are requested to check in the absence of the owners or tenants; and the public interest in nondisclosure outweighs the public interest in disclosure in this particular instance.
- Requested record(s) are records of security measures.
- Requested record(s) are information relating to a civil action in which the requesting party and the public body are parties.
- Requested record(s) would disclose the social security number of an individual.
- Granted in part, denied in part, see above for explanation, record(s) enclosed.

- Due to unusual circumstances, as stated below, we are extending the period to respond to your request by ten (10) business days, your request will be granted, denied, or granted in part and denied in part by _____. (Response Date)
- The need to search for, collect, or appropriately examine or review a voluminous amount of separate and distinct public records pursuant to a single request.
- The need to collect the requested public records from numerous field offices, facilities, or other establishments which are located apart from the particular office receiving or processing the request.

If your request for record(s) is denied, you may submit a written appeal, specifically stating "appeal" and stating the reasons for appeal, to the Ludington City Council, or seek judicial review under Section 10 of the Act within 180 days after the public body's final determination. Within ten (10) days of receiving a request for an appeal, the City Council shall a) reverse the denial; b) issue a written notice upholding the denial; c) reverse in part and uphold in part by written notice; or d) issue a notice extending by ten (10) business days the time to decide the appeal. The City Council is considered to have received your appeal at its first regularly scheduled meeting following the submission of the appeal in writing.

If after judicial review, the Circuit Court determines that the City of Ludington has not complied fully with the disclosure requirements, the Court shall award reasonable attorneys' fees, costs, and disbursements. If the Court determines that the City of Ludington has arbitrarily and capriciously violated the Act, the Court shall award punitive damages in the amount of \$500.00.

A copy of this request will be kept on file for no less than one (1) year.

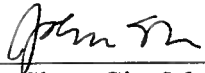

John Shay, City Manager
FOIA Coordinator



JOHN HENDERSON, MAYOR
JOHN E. SHAY, CITY MANAGER
DEBORAH L. LUSKIN, CITY CLERK
LINDA J. ROGERS, CITY TREASURER

CITY OF LUDINGTON

400 SOUTH HARRISON STREET
LUDINGTON, MICHIGAN 49431
PHONE (231) 845-6237
FAX (231) 845-1146

MEMORANDUM

TO: Mayor Henderson and the Ludington City Council
FROM: John Shay, City Manager 33
DATE: August 24, 2012
RE: McAdam Lawsuit Against City

Allan Vander Laan, who is the attorney assigned by the City's liability insurer (MMRMA) to defend the City in this lawsuit, will attend the City Council meeting. He will discuss the status of this lawsuit in closed session.

On the Shores of Lake Michigan

LUDINGTON CITY PLANNING COMMISSION

AGENDA

Tuesday

September 4, 2012

7:00 P.M.

**Ludington Municipal Building
400 S Harrison, Ludington, MI 49431**

1. Call to Order
2. Roll Call
3. Agenda Approval
4. Public Comments & Communications
5. Approval of Minutes:
August 8, 2012
6. Public hearings
 - a. To consider a request from Blu Moon Properties, LLC for a special land use for the outdoor service of food and beverage, in accordance with Section 400.8:4 (5) of the Ludington Zoning Ordinance #23-00, at the following described property:
ORIGINAL PLAT N 25 FT OF S 56 FT OF LOTS 6 & 7 BLOCK 35, EXCEPT E 10 FT FOR ALLEY PURPOSES, also known as 125 S. James St.
7. Unfinished Business:
 - a. Signs
8. New Business
9. Site Plan Review Report:
10. Commissioners' Comments and Communications
 - a. Downtown Ludington Board Report
11. Adjournment

**PLANNING COMMISSION
MINUTES
August 8, 2012**

A meeting of the Ludington Planning Commission was held on Wednesday, August 8, 2012. The meeting was held at the Ludington Municipal Building, 400 S. Harrison St., Ludington, MI and was called to order at 7:00 p.m. by Mike Nekola, Chairperson.

ROLL CALL: The roll call showed the following results:

Present: Kirk Josvai, Chris Gamble, Mike Nekola, Roger Starr, Lynn Pontz, and Kaye Holman,
Absent: Robert Sasin, excused, Mike Lenich, excused and John Kreinbrink, absent

Also Present: Carol Ann Foote, Recording Secretary

AGENDA APPROVAL:

Commissioner Holman made a motion to approve the agenda seconded by Commissioner Pontz. Motion carried unanimously.

PUBLIC COMMENTS:

None

APPROVAL OF MINUTES:

Commissioner Gamble made a motion to approve the July 10, 2012 minutes, seconded by Commissioner Josvai. Motion carried unanimously.

PUBLIC HEARINGS:

- a. To consider changes to the Ludington Zoning Map in order to rezone the following parcels from WM2 (Waterfront Maritime 2) to WCB (Waterfront Central Business District): Original Plat Lots 6, 7, 8, 9 and 10 Block 47.

Chairman Nekola explained that this rezoning would allow more commercial uses but lower heights than Central Business District. If rezoned to WCB, single-family homes would not be a permitted use.

Sheryl Stapert, 201 S. William, Unit 21, asked how this rezoning would affect One Ludington Place. Chairman Nekola explained that WCB zoning would allow various uses that were more commercial. Commissioner Gamble stated that WCB was the same zoning as the condominiums. The vacant land north of the condos would have zoning comparable to theirs. Chairman Nekola read the permitted uses and special land uses that would be allowed. Ms. Stapert asked how this came about. Chairman Nekola explained that there had been a request to allow single-family residences in the WM2 zoning district, but it was decided that single-family would not be an appropriate use in the "Wesco" block. Commissioner Pontz said that would allow single-family in the two blocks west, but not the "Wesco" block.

Close public hearing.

The recording secretary reported that 86 notices were sent with no written response.

Commissioner Pontz made a motion to recommend to City Council to rezone the following parcels from WM2 (Waterfront Maritime 2) to WCB (Waterfront Central Business District): Original Plat Lots 6, 7, 8, 9, and 10, Block 47, seconded by Commissioner Holman.

Commissioner Gamble asked how the zoning committee felt about the rezoning. Commissioner Josvai stated that the committee felt that it should be rezoned to WCB.

Motion carried unanimously.

- b. To consider a text change to the Ludington Zoning Ordinance #23-00, Article 400.17 WM1 and WM2 (Waterfront Maritime), Section 400.17:2, Permitted Principal Uses, to allow single-family residential in the WM 2 district as listed below: Original Plat, Lots 7, 8, 9, 10, 11 and 12, Block 48 and Original Plat, Lots 9,10, 11 and 12, Block 49

Sheryl Stapert, 201 S. William, Unit 21, asked if single-family residences would be allowed in the area south of Lakewinds Dental. Chairman Nekola explained that this would be adding single-family residences to the WM2 district. He read the permitted and special land uses that were allowed in that district.

Close public hearing.

The recording secretary reported that 95 notices were sent with no written response.

Commissioner Josvai made a motion to recommend to City Council to approve text changes to Ludington Zoning Ordinance 23-00, Article 400.17, WM1 and WM2 (Waterfront Maritime), Section 400.17:2, Permitted Principal Uses, to allow single-family residential in the WM2 district as listed below: Original Plat, Lots 7, 8, 9, 10, 11 and 12, Block 48 and Original Plat, Lots 9, 10, 11 and 12, Block 49, seconded by Commissioner Pontz. Motion carried unanimously.

UNFINISHED BUSINESS:

a. Signs:

No report

SITE PLAN REVIEW:

Commissioner Josvai reported that a site plan review was held in July for a proposed addition to Western Land Services located in the Industrial Park. Commissioners Josvai and Pontz met with City officials and the contractor. There were no major concerns. There will be no impact to City services and the Fire Chief had no concerns. The site plan was approved, as submitted.

COMMISSIONERS COMMENTS

Downtown Ludington Board:

No report

Commissioner Pontz to the Commission that he talked to Commissioner Lenich regarding signs for businesses not located on Ludington Ave. He suggested that signs like the directional signs installed by the downtown committee might be pursued. He commented that he was very encouraged to see the Mayor and others spear-heading a sunset activity Friday night. He said that he felt that it has been long needed.

ADJOURNMENT:

Motion was made by Commissioner Holman, seconded by Commissioner Josvai, to adjourn the meeting. The meeting adjourned at 7:25 p.m.

Respectfully Submitted,
Carol Ann Foote, Recording Secretary

Chris Gamble, Secretary

\$200.00

CITY OF LUDINGTON
Department of Building & Zoning
400 S Harrison, Ludington, MI 49431
Phone: (231) 843-2956 FAX: (231) 845-1146

APPLICATION FOR PLANNING COMMISSION PUBLIC HEARING:

Meeting Date: Sept. 4, 2012
Deadline - Aug. 13-14

- Special Land Use
- Expansion of a Non-Conformance
- Rezoning
- Text Change
- PUD
- Other: _____

Address: 125 SOUTH JAMES STREET blu moon
or
Area Description: _____

Applicant's Name: RANDY & MARILYN CUNIC Owner Name: RANDY & MARILYN CUNIC
 Applicant's Address: 125 1/2 SOUTH JAMES ST. Owner Address: 125 1/2 SOUTH JAMES ST.
 Phone No. 233 1254 Phone No. 233 1254

REASONS FOR REQUEST: EXPANSION OF OUR CURRENT DECK
TO INCWDE 125 SOUTH JAMES

ZONING ADMINISTRATOR'S COMMENTS: A special land use was approved on
11/11 for an outdoor deck to serve food and beverage at
121 S. James. This request is to expand this use to
125 S. JAMES - (Section 400.8.4(5) (900.3:21)

Randy Cunic
Applicant's Signature
Carol C. Foote
Zoning Administrator's Signature

Date: 8/13/12
Date: 8/13/12

Legal Description of parcel: original Plat N 25ft of S 50ft
of lots 6+7 Block 35, Except E 10ft
for Alley purposes-

Present Zoning: CBD
Adjacent Zoning: CBD
Adjacent Land Uses: Commercial

Proposed Zoning: NA

PROPOSED DEVELOPMENT: proposed Deck Addition
to 125 S James-

APPLICATION MUST BE FILED WITH THE BUILDING DEPARTMENT AT LEAST EIGHTEEN DAYS BEFORE MEETING DATE SO ALL PROPER NOTIFICATIONS CAN BE MADE OF PUBLIC HEARING.

NOTE: (for Special Land Use Requests) ALL APPLICANTS ARE REQUIRED TO SHOW IN WRITING HOW THE STANDARDS LISTED BELOW WILL RELATE TO THEIR PROJECT.

Section 900.2:6 Standards. No Special Land Use shall be approved by the Planning Commission unless the commission finds:

- (1) That the establishment, maintenance, or operation of the special land use will not be detrimental to or endanger the public health, safety, or general welfare.
- (2) That the special land use will not be injurious to the use and enjoyment of other property in the immediate vicinity for the purposes already permitted, nor shall it substantially diminish and impair property values in the neighborhood.
- (3) That the establishment of the special land use will not impede the normal and orderly development and improvement of the surrounding property for uses permitted in the district.
- (4) That adequate utilities, access roads, drainage, and necessary facilities have been or are being provided.
- (5) That adequate measures have been or will be taken to provide ingress or egress so designed as to minimize traffic congestion in the public streets.
- (6) That the special land use shall, in all other respects, conform to the applicable regulations of the district in which it is located and to any additional conditions or procedures as specified in CHAPTER IV.

Filing Date: 8-13-12
Appeal Fee: 200.00
Receipt No: 94072

REQUIREMENTS:

(1) Up to two copies of the proposed site plan shall be filed with the application and shall include as a minimum the following:

(a) The plan shall be drawn to a scale of not greater than one inch equals 20 feet for a development of not more than three acres and a scale of not less than one inch equals 100 feet for a development in excess of three acres.

(b) The plan shall show an appropriate descriptive legend, north arrow, scale, date of preparation, and name and address of the individual or firm preparing the same.

(c) The property shall be identified by lot lines and general location together with dimensions, angles, and size correlated with the legal description of the property.

(d) The topography of the site with at least two-foot contour intervals and all natural features such as wood lots, streams, rivers, lakes, wetlands, unstable soils and similar features shall be shown.

(e) Existing man-made features upon the site and within 100 feet of the site shall be indicated.

(f) The location, proposed finish floor and grade line elevations, size of proposed main and accessory buildings, the relationship of buildings to one another and to any existing structures on the site, the height of all buildings and square footage of floor space therein shall be indicated. Site plans for multi-family residential development shall also include a density schedule showing the number of dwelling units per acre, including a dwelling schedule showing the unit type and number of each such unit.

(g) All proposed and existing streets, driveways, sidewalks, and other vehicle or pedestrian circulation features upon and adjacent to the site shall be shown, together with the location, size, and number of parking spaces in off-street parking areas, service lanes thereto, and service parking and delivery or loading areas.

(h) The location, use, and size of open spaces together with landscaping, screening, fences, walls, and proposed alterations of topography or other natural features shall be indicated.

(i) The proposed operations on the site shall be described in sufficient detail to indicate the effect, if any, upon adjoining lands and their occupants, together with any special features which are proposed to relieve any adverse effects to adjoining lands and their occupants. Any potential demands for future community services will also be described, together with any special features which will assist in satisfying such demands.

(j) Any earth-change plans required by state law, shall also be submitted with the application.

(k) On-site lighting, surface water drainage for the site, and proposed sanitary sewage disposal and water supply shall be included in the plans.

(l) Such other information as may be determined to be necessary by the Site Plan Review Committee because of any peculiar features of the proposed development.

(2) The Site Plan review Committee may waive any of the requirements in subsection (1) when, in the opinion of the Site Plan Review Committee, such requirement(s) will not be a significant factor(s) in the Site Plan Review process for that particular use.



August 8, 2012

To: Carol Ann Foote

From: Marilyn and Randy Cunic; the Blu Moon Bistro

We are respectfully submitting a request for special land use of the roof top space over our current business. Due to the success of our 1st rooftop deck this summer, we are considering adding a 2nd rooftop, open air seating deck above the two story space (the original Blu Moon) at 125 S. James Street. This 2nd deck would provide seating only (no kitchen or restrooms). Our current kitchen and restrooms on the first deck would service this 2nd level. An overwhelming benefit to this addition is that there is a clear view of Lake Michigan and the Car Ferry from this level.

As promised with the addition of our 1st deck, we have created more than 10 jobs for Ludington, increased our business by capitalizing on our summer traffic, added a unique option to downtown Ludington with an outdoor rooftop experience that has been full much of the time, and increased foot traffic to other businesses in the area. In fact, it has become our practice while customers are on a wait, to offer to take their cell phone number while they "shop in our great stores downtown" and we'll call them when their table is ready. They love this option and they usually come back with a shopping bag as a result.

We expect that this next addition of space would provide the same benefits as follows:

1. Increase and expand our current business
2. Capitalize on our summer traffic
3. Add interest and a unique option w/open seating dining in our downtown area
with a view of the Lake and S.S. Badger
4. Create jobs
5. Increase foot traffic to other businesses in the area

We have provided very preliminary renderings of our intention. We have secured Adam KozECKi as our builder and general contractor, and if we are able to move forward on this project, actual architectural drawings would be created at that time, supported by Jim Nordlund Engineering. We would ensure all codes and regulations are met if we are able to proceed, we would hope to be able to open and use this space by next summer season.

As always we thank for your support.

Marilyn and Randy Cunic

Blu Moon Bistro



Section 900.2:6 Standards.

1. That the establishment, maintenance, or operation of the special land use will not be detrimental to or endanger the public health, safety, or general welfare.
 - The operation and maintenance of this deck is simply an extension of our current core business.
2. That the special land use will not be injurious to the use and enjoyment of other property in the immediate vicinity for the purpose already permitted, nor shall it substantially diminish and impair property values in the neighborhood.
 - Other properties in the immediate vicinity include a Gaming Store, a Tattoo Shop, a Music Store and a Used Book store. The addition of a rooftop deck will in no way interfere or diminish other businesses in our neighborhood. In fact this could increase the value and add foot traffic to our adjoining businesses.
3. That the establishment of the special land use will not impede the normal and orderly development and improvement of surrounding property for uses permitted in the district.
 - The addition of a rooftop deck will in no way impede the normal and orderly development and improvement of surrounding property for uses permitted in the district.
4. That adequate utility, access road, drainage and necessary facilities have been or are being provided.
 - Yes, all are already in place now.
5. Those adequate measures have been or will be taken to provide ingress or egress so designed as to minimize traffic congestion in public streets.
 - Adequate measures already exist and nothing additional should be required for the purpose of adding seating to our existing establishment.
6. That the special land use shall, in all other respects, conform to the applicable regulations of the district in which it is located and to any additional conditions or procedures as specified in CHAPTER IV.
 - We will conform to all applicable regulations of the district in which we are located and to any additional conditions or procedures as specified in CHAPTER IV.

-N-

PROPOSED BLU MOON DECK ADDITION

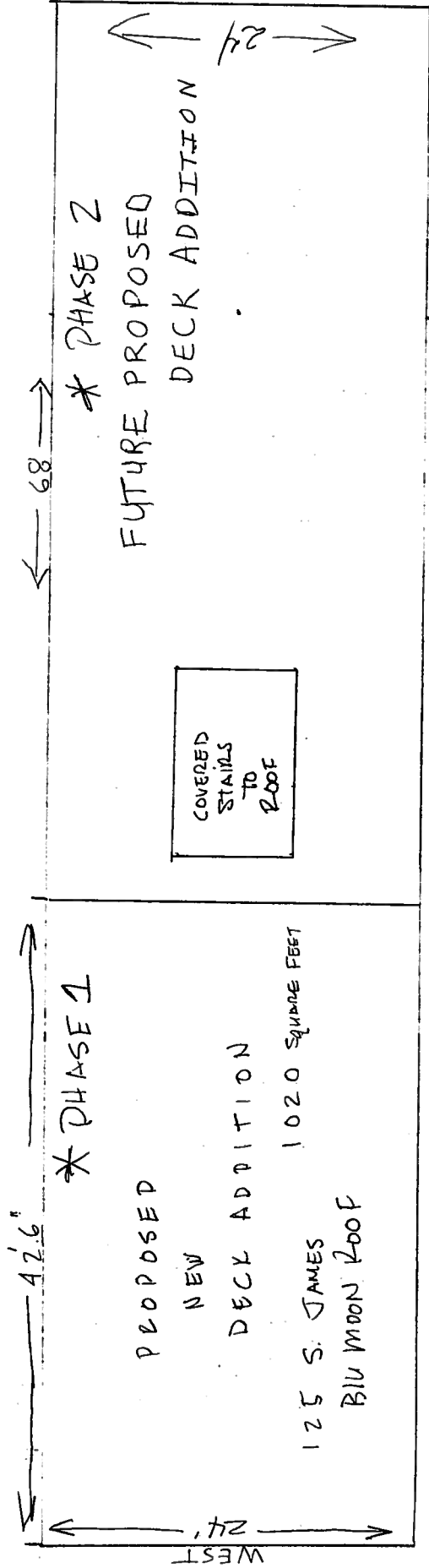

The Blu Moon: New Rooftop Dining Area

DATE:	03.22.12
DRAWN BY:	SH
ISSUED:	
OWNER REVIEW:	03.22.12
OWNER REVIEW:	01.17.12
ENGINEER REVIEW:	01.06.12

**BUILDING
 SECTION**

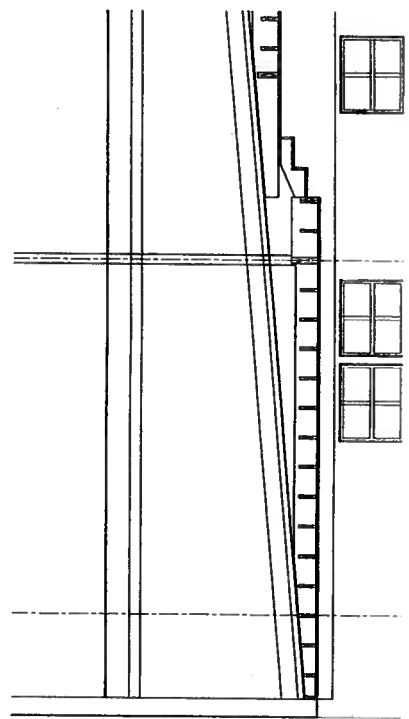

02 EAST-WEST SECTION
 A4.1 SCALE 1/8" = 1'-0"

01 A4.2

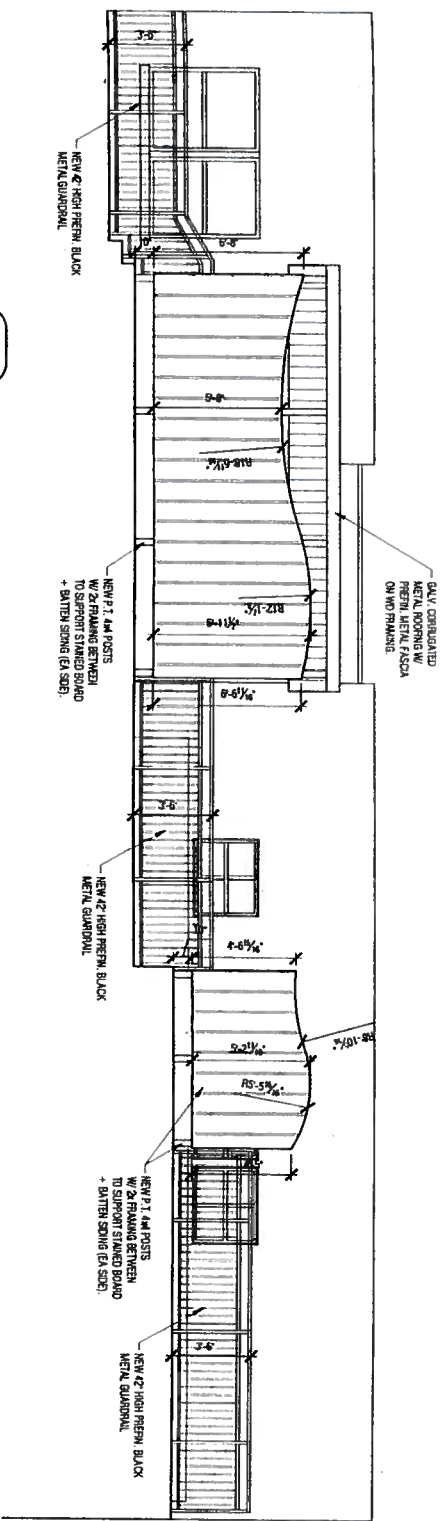

04 NORTH ELEVATION
 A2.1
 SCALE: 1/4" = 1'-0"

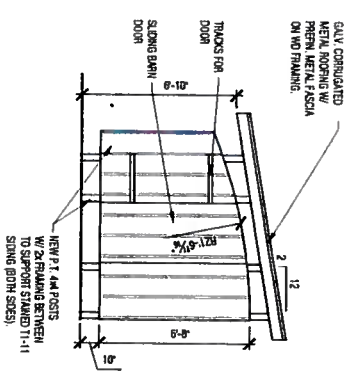

03 EAST ELEVATION
 A2.1
 SCALE: 1/4" = 1'-0"

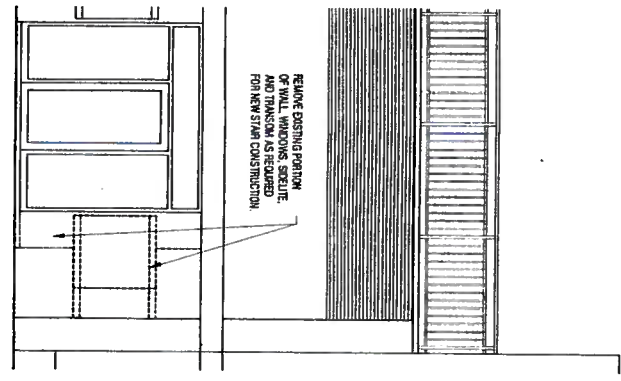
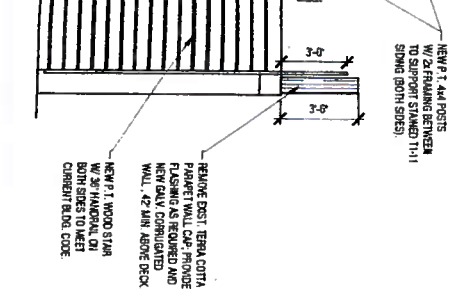
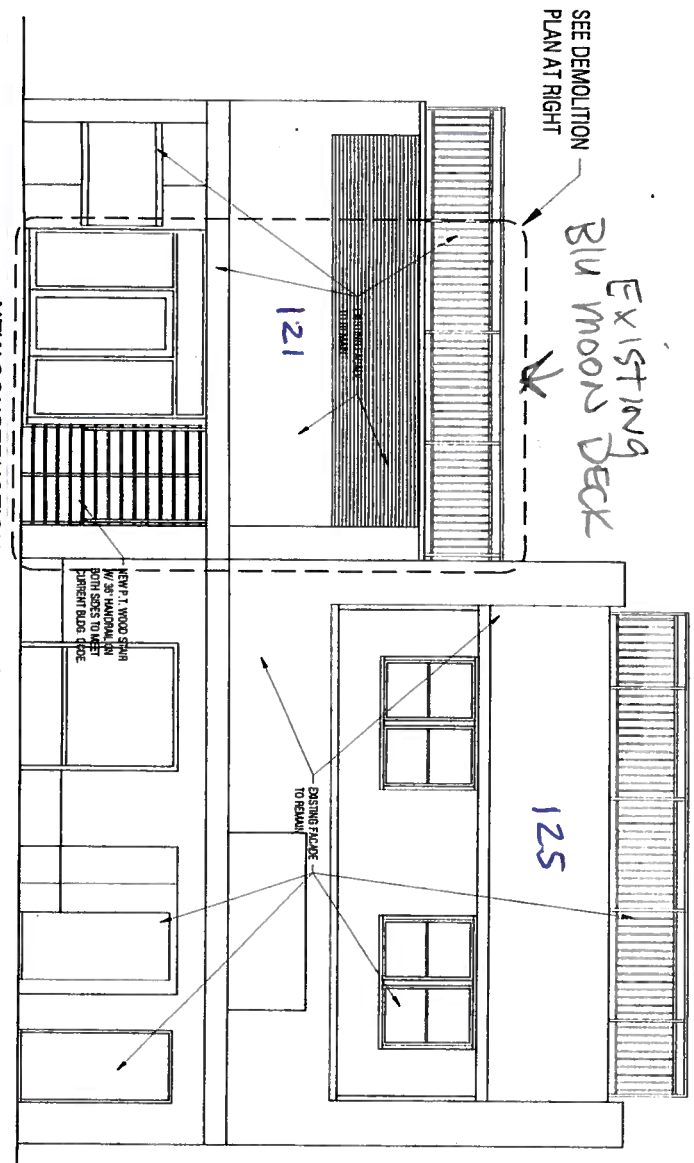

DATE: _____
 DRAWN BY: _____
 ISSUED: _____
 OWNER REVIEW _____
 OWNER REVIEW _____
 EXT ELEV.

FRONT VIEW



SIDE VIEW

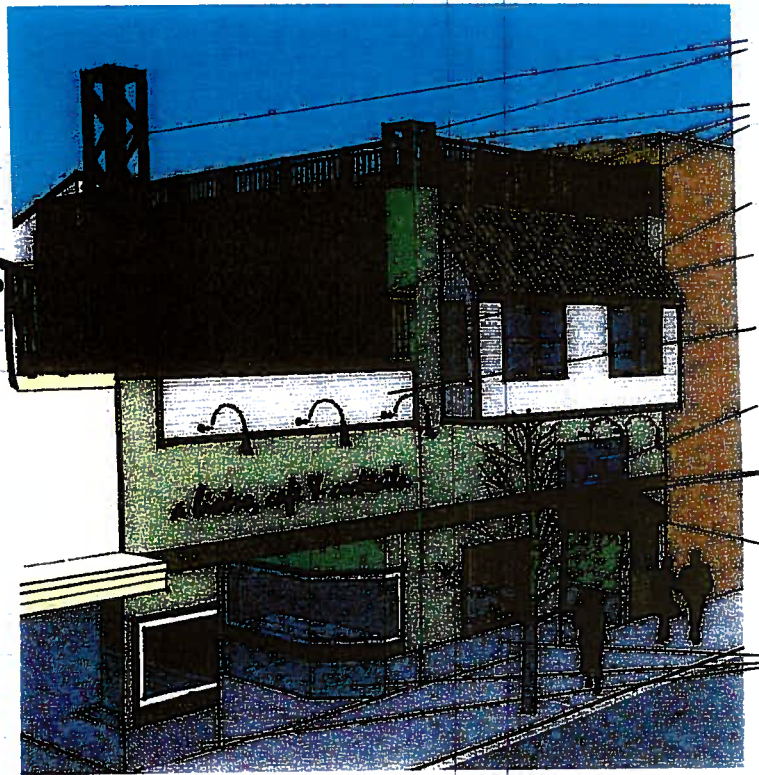

**CITY OF LUDINGTON
BOARD OF ZONING APPEALS
LUDINGTON MUNICIPAL BUILDING
400 S HARRISON ST., LUDINGTON, MI 49431**

AGENDA

Thursday, September 6, 2012

5:30 P.M.

1. Call to Order
2. Roll Call
3. Agenda Approval
4. Approval of Minutes:
March 5, 2012
5. Public Hearing:
Consideration of a request by John W. Fisher for a side yard setback variance in order to complete construction of a single-family home within six feet, ten inches (6' 10") of the south side yard property line. Ludington Zoning Ordinance 23-00, Section 400.14 requires a minimum of a seven and one-half feet (7' 6") side yard setback.: PART OF LOTS 31, 32 & 33 BLK 1 ASSESSORS PLAT OF SIXTH ADDITION TO THE CITY OF LUDINGTON, BING THE N 150 FT OF THE N 1/2 OF THE SW 1/4 OF THE NW 1/4: DESC AS COM AT THE W 1/4 COR OF SEC 10; TH S 00 DEG 30' 25" E ALG THE W LINE OF SEC 10, 661.76 FT; TH N 87 DEG 46' 48" E PARALLEL WITH THE N LINE OF THE N 150 FT OF THE N 1/2 OF THE SW 1/4 OF THE NW 1/4 OF SEC 10, 159.90 FT TO THE E LINE OF A VACATED ALLEY; TH S 00 DEG 31' 04" E ALG THE E LINE OF THE VACATED ALLEY, 75.04 FT TO POB; TH N 87 DEG 46' 48" E PARALLEL WITH THE N LINE OF THE N 150 FT OF THE N 1/2 OF THE SW 1/4 OF THE NW 1/4 , 139.91 FT TO THE W ROW LINE OF VOGEL ST AS PLATTED; TH S 00 DEG 31' 43" E ALG THE W ROW LINE OF VOGEL ST, 75.03 FT TO THE S LINE OF THE N 150 FT OF THE N 1/2 OF THE SW 1/4 OF THE NW 1/4; TH S 87 DEG 46' 48" W PARALLEL WITH THE S LINE OF THE N 150 FT OF THE N 1/2 OF THE SW 1/4 OF THE NW 1/4, 139.92 FT TO THE E LINE OF A VACATED ALLEY; TH N 00 DEG 31" 04" W ALG THE E LINE OF THE VACATED ALLEY, 75.03 FT TO P OF BEG SEC 10 T18N R18W 0.24 AC +/-, also known as 1011 Vogel St.
6. Old Business:
7. New Business:
8. Public Comments & Communications
9. Adjournment

CITY OF LUDINGTON
ZONING BOARD OF APPEALS
Minutes – 03-05-12

A regular meeting of the Ludington Board of Zoning Appeals was held on March 5, 2012 at the Ludington Municipal Building, 400 S Harrison St., Ludington, MI, and was called to order by Brian Purtee, Chairperson at 5:30 p.m.

PRESENT: Brian Purtee, Tracy Hutchinson, and Kathy Winczewski

ABSENT: Roger Starr

ALSO PRESENT: Recording Secretary Carol Ann Foote

ROLL CALL:

The roll call gave the above results.

AGENDA APPROVAL:

A motion was made by Tracy Hutchinson to approve the agenda seconded by Kathy Winczewski. Motion carried unanimously.

MINUTES:

A motion was made by Kathy Winczewski to approve the minutes of April 19, 2011 seconded by Brian Purtee. Motion carried unanimously.

PUBLIC HEARING:

Consideration of a request by Keith Kolfage and Suzette Hodges-Kolfage for a twelve foot setback variance in order to construct a 12 x 18 sunroom at the following described property:

KASSON'S ADDITION LOTS 9, 10, 11 & 12, EXCEPT THE N 120 FT OF LOTS 11 & 12, BLOCK 1, AND THAT PARCEL OF LAND BOUNDED ON THE N BY THE S LINE OF LOTS 9 - 12 OF BLOCK 1, ON THE E BY E LINE OF LOT 12 PROJECTED S TO LUDINGTON AVE, ON THE W BY THE WESTLINE OF LOT 9 PROJECTED S TO LUDINGTON AVE., AND ON THE S BY THE NORTH LINE OF LUDINGTON AVE. ALSO IN KASSON'S ADDITION, THE S 60 FT OF THE N 120 FT OF LOTS 11 & 12, BLK 1, also known as 717 E. Ludington Ave.

Keith Kolfage, 107 N. Franklin St., told the members that he and his wife operate the Four Seasons Lodge, soon to become known as Summer's Inn Ludington. The reason they are here is a need to change the business as the market changes. We have provided our reasons for that which is mainly market driven. As far as feasibility, we have studied other options which are much more expensive, very unpractical. The big indicator of change is traffic. A business like ours is very dependent on the traffic in town. We are going in such way, long term, where someone driving down the road would not spontaneously say let's stay here, but they would consciously say that they would like to come to this place. One thing that is important is that we are adult driven. Again this year, we are a property that appeals to singles and couples. A big thing this year is no children. We are reaching to a market that is driven by cultural tourism, the arts and things of that sort. To do that we need to address concerns that our guest have had. We feel that it will be a good addition to the Avenue. We provided drawings that we had rendered by Stacy Hadeed, licensed architect. Mr. Kolfage approached the members and submitted different renderings of the views and elevations. He said that there would be minimal impact on the Avenue. The proposed room would be built over the existing concrete patio. Mr. Kolfage pointed out the ramp and the ADA accessibility. He said that looking at the impact on the neighborhood, is the change. The surrounding properties are mostly zoned multi-family. Up until about 2006, there were mostly owner-occupied properties. The property across Franklin St. has been converted into rentals. What we are seeing is the neighborhood becoming more business orientated, in a sense, and less family orientated. They are no longer in the realm of impacting the neighborhood where they have a single family, owner-occupied business. He pointed out that across the street there was a nicely restored Victorian home, then going east are multi-family

Zoning Board of Appeals
Meeting Minutes
03/05/12

rental homes. He said he was trying to point out that the neighborhood had changed with more B & Bs and income type homes.

Tracy Hutchinson asked about the layout of the interior of the room. Mr. Kolfage said that it would be a room with a concrete floor. They may dye the floor and polyurethane it. He said that they do a lot of recycling and would be recycling in the interior. Some of the seating from the breakfast area will be brought into the sunroom and rearranging the seating for more space. Ms. Hutchinson asked if the room was one open space or was it broken down into different areas like storage. Mr. Kolfage said that right now that space was 1,200 square feet. That space is divided into the kitchen and check in. In the kitchen is a convection oven for baking. All of the products that are used, we make them or they are local products other than one Kellogg's product. On the other side of the kitchen going west is check in and seating for twenty-four.

Tracy Hutchinson asked how they were in regards to parking. Mr. Kolfage explained that in 2006 they took four rooms out of service because of too much capacity for the market. The rooms are now being used for storage. The parking was originally for thirty-three rooms and now there are twenty-nine. We are seeing an up-kick in occupancy being at 60%. So, 40% of the time there is excess capacity.

Tracy Hutchinson asked what options were looked at other than expanding to the south. Mr. Kolfage said that his architect, Stacy Hadeed, did go over some of the other options with them. Because they are a small business, if they move space to other areas they have to provide personnel to service that area. Where they are now, they do not have to move personnel, alter the drive or expand the electricity. We would not have to tear up a parking lot and put in a foundation. To do this somewhere else could not happen financially. It would create a greater disturbance. It would disrupt mature landscaping and things of that sort.

Kathy Winczewski wanted to know if their goal was to have the sunroom with the breakfast room. Mr. Kolfage said that one of their goals was to have a place to have WI-FI. They also have a fireplace. He stated that it was very attractive. There are French doors that open into the patio. The patio space was never too successful. One reason for that is the noise on Ludington Ave. Consequently, there are not a lot of other options. Even a temporary structure would require us to come before the zoning board. It is the only way we can use the space or it will become obsolete. Suzette Kolfage said that they put the pad in the front for people to sit outside. When the office is closed, kids were using it at night. It became a problem area. She said she would be more comfortable if it was not open.

Tracy Hutchinson asked about the area in the northeast corner that steps down. She asked if that area could be used as a sitting area with WI-FI. Keith said that people do use that area to sit and read, but WI-FI has been a challenge. It would need to be cabled in with repeaters, but there is no way to get into that section. Mrs. Kolfage said that they used to serve breakfast in that area, but trying to carry food and to keep it clean and safe was impossible. Mr. Kolfage said that there was a lot of outdoor space for the guest. This area services the string of small rooms. Guest that book these rooms are usually traveling with parents. They use the area as a getaway.

Tracy Hutchinson asked if they had done a feasibility study of moving the laundry room. Mr. Kolfage said that the plumbing is under the slab. To move anything would mean cutting floors to extend this type of plumbing. They have a designated hot water tank that does nothing but service the laundry area. The laundry is also down a grade, about four steps down. Even moving the laundry room would not address any of our issues.

Kathy Winczewski asked if there was anywhere in the courtyard that a sunroom could go. Mr. Kolfage said that there was a pond and a garden there and a large investment of material and time. You would have to extend utilities. It becomes tough in terms of two electric services on property.

Zoning Board of Appeals
Meeting Minutes
03/05/12

Tracey Hutchinson asked about the building on Franklin. Mr. Kolfage said it was a rental home built in 1950 that was converted it.

Suzette Kolfage said moving anything north would mean that nothing would be ADA compliant.

Kathy Winczewski asked if they thought about putting a railing up around the patio to discourage anyone from using it in the evenings. Mr. Kolfage said that the patio was very loud during the summer.

Kaye Holman stated that the patio was ADA and that was required by law. Changes could create problems.

Close Public Hearing

The recording secretary reported that 66 notices were sent to the surrounding property owners and there was no response. She also reported that a letter from Roger Starr, Chairman, had been forwarded to the members. Brian Purtee read Mr. Starr's letter to the members.

Practical difficulties: Brian Purtee explained that a practical difficulty is something that keeps one from complying with the ordinance.

Kathy Winczewski said there is a difficulty, but there are options. Brian Purtee said that he did not see a practical difficulty.

Detrimental to adjacent properties: Kathy Winczewski said that she had concerns about the house to the west. Their view of Ludington Ave. would change because they are higher. But it might take some road noise away. Brian stated that they had to be aware that this sort of variance was forever. We are not granting the variance to the owner, but to the property. Tracy Hutchinson said that she looked at the other rentals and B & Bs along the Avenue and thought what if they all wanted to move forward to within 12 ft. of the property line. The Kolfage property is a little bit hidden and they have done great landscaping. The existing patio is in a little nook. What if the others, such as the Doll House wanted to move forward?

Variance is in harmony with the Ordinance: Brian Purtee said that he does not believe it does. The Planning Commission, in the past, has been very protective of Ludington Ave. Several years ago, someone from a business close by came in for additional signage space. The Planning Commission addressed that and thought it was a very bad idea.

Alleged hardships or practical difficulties include more than persona inconvenience/financial hardship: Brian Purtee said that it was a gray area because they are talking business. There are other alternatives. They would involve landscaping and expense, but there are alternatives. Tracy Hutchinson agreed.

Kathy Winczewski commented to the Kolfages. She said that she was not familiar with the business, but did walk around it a couple of times. She was extremely impressed by the landscaping and the overall look of the suites on Franklin St. She said that they had to make a decision for the future; they had to make it for the whole land and not just what they had done. She thinks that they have done a good job and it looks beautiful. The marketing for the business sounds interesting and she thinks they will be successful with it. We have to uphold the Planning Commission's decisions. She said that she felt that their request was valid.

Kathy Winczewski made a motion to approve the 12 ft. setback variance, seconded by Brian Purtee.

Zoning Board of Appeals
Meeting Minutes
03/05/12

Roll call vote: Winczewski, no Hutchinson, no Purtee, no
Motion failed and the request was denied.

Brian Purtee told Mr. Kolfage of the appeals process.

OLD BUSINESS:

None

NEW BUSINESS:

Election of Officers:

Chairman:

Bryan Purtee nominated Roger Starr for Chairman, seconded by Kathy Winczewski. Nominations were closed.
Motion carried unanimously.

Kathy Winczewski nominated Brian Purtee for Vice-Chairman, seconded by Tracy Hutchinson. Nominations
were closed. Motion carried unanimously.

The meetings were set for the third Tuesday of the month, as needed, at 5:30 p.m. at City Hall.

COMMENT AND COMMUNICATIONS:

None

ADJOURNMENT:

Kathy Winczewski made a motion to adjourn seconded by Brian Purtee. Meeting was adjourned at 6:20 p.m.

Respectfully submitted,
Carol Ann Foote, Recording Secretary

**CITY OF LUDINGTON
BOARD OF ZONING APPEALS
400 S. HARRISON ST.
LUDINGTON, MI 49431**

August 21, 2012

To: Board Members
From: Carol Ann Foote, Zoning Administrator

RE: Variance request: 1011 Vogel St.

On July 12, 2012, a building permit for a single-family home was secured for 1011 Vogel St. The contractor for the project, Jason Porter, submitted plans and a site plan for the project. The site plan indicated that there would be 7 ½ ft. setbacks on each side of the property which met Ordinance requirements.

It was later discovered that a mistake had been made in measuring the property and the south side of the house is actually 6'10" from the property line and not the required 7 ½ ft. This means that they need a side-yard setback variance of 8".

CITY OF LUDINGTON, MICHIGAN
Department of Building & Zoning
400 S Harrison., Ludington, MI 49431
Phone: (231) 843-2956 FAX: (231) 845-1146

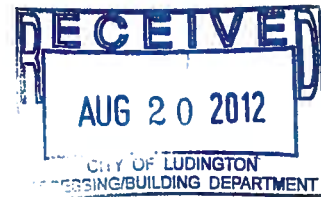

APPLICATION FOR BOARD OF ZONING APPEALS PUBLIC HEARING

All Information needs to be in by 8/20
Your Hearing will be 9/6

NOTICE TO APPLICANT: Meetings of the Board of Zoning Appeals (BZA) are scheduled for the *third Tuesday of the month*. These meetings are held at 5:30 p.m. at the City Municipal Building, 400 S Harrison St., Ludington, MI. Application with all required information and applicable fees must be submitted to the Building Inspector's office at least **EIGHTEEN (18) days prior** to the meeting. No action will be taken until all information is submitted.

BACKGROUND INFORMATION: The Board of Zoning Appeals is created to offer reviews and decisions when an interpretation of the Zoning Ordinance or zoning district boundary is questioned, when an order or decision of an administrative official or body is questioned, when the Zoning Ordinance empowers the Appeal Board to hear specific uses, or when a variance from the strict interpretation of the ordinance is sought to avoid a specific hardship. A hardship must involve a unique situation rather than one which represents a minor inconvenience. The Appeal Board is not a legislative body, it does not have the power to rezone or change uses. Any decision of the Appeals Board must comply with the basic spirit (intent) of the Ordinance while maintaining the public health, safety and welfare of the area and the community at large. If your request represents a significant change from the established intent, then an amendment to the Zoning Ordinance may be the proper solution.

GENERAL REQUIREMENTS: In order to expedite your request, it is required that you submit certain basic information to allow the Board of Zoning Appeal members the opportunity to properly understand and consider the request.

When providing the required information, you may attach any additional or supplemental information you feel will be useful to the Board members in their deliberations.

It is up to the applicant to prove to the Board that a hardship or practical difficulty exists. It must be shown that the request cannot be done according to what is required by the zoning ordinance. For example, the way the land is shaped or contoured may prevent the request from being placed according to what the ordinance requires.

Date Application Rec'd 8/20/12
Received By [Signature]
Fee Paid \$ 200 Receipt No 94427

BOARD OF ZONING APPEALS - REQUEST FOR PUBLIC HEARING

I. Name of Applicant/Owner

A. Applicant

- 1. Name(s) John Fisher
- 2. Address(s) 610 4th St. Ludington, MI 49431
- 3. Phone No.(s) 231-690-5957

B. Owner of property if different than above

- 1. Name(s) _____
- 2. Address(s) _____
- 3. Phone No.(s) _____

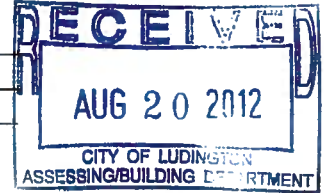

II. Location of Property:

A. Street name and number: 1011 Vogel St.

B. Indicate location of site on copy of the City of Ludington Zoning Map (or similar map) and attach to the application.

C. A drawing(s) indicating the following information shall also be attached to the application (such drawing shall be to scale):

- 1. A drawing of the subject site, lot, etc., with property line dimensions shown.
- 2. The size and location of existing buildings and specific uses on the site.
- 3. The size and location of any proposed buildings and/or uses on the subject site.
- 4. Existing buildings and/or uses on adjacent properties.
- 5. Existing and proposed *setbacks* to buildings on the site and to buildings on *adjacent* parcels along any common property lines.
- 6. Such building floor plans and/or or structural elevations which may be important in determining building height, use areas, and/or development needs.

III. What specifically are you requesting?

To leave house 6'10" away from south property line.

IV. Effect on you. Explain the *specific* reasons that you cannot adhere to the strict letter of the Zoning Ordinance. What are the *unique* conditions which apply to your property or request as opposed to other properties under your same zoning requirements?

This would not have an effect on me

V. Effect Other Properties If your request is granted, what effect will it have on the area.

I do not see any effect this would have by having the home
a few inches closer to the property line

NOTE: At the public hearing, the BZA may take the following actions:

1. Approve the request subject to the terms and conditions set forth in the application.
2. Approve the request subject to amended and/or additional terms and conditions they feel are reasonable and appropriate to maintain the public health, safety and welfare. This may also include financial or other guarantees that will ensure your compliance with the stated terms of approval.
3. Deny the request as not being in the public interest and as being contrary to the basic spirit and intent of the Zoning Ordinance.
4. Table the request pending clarification of any additional problems or questions which may arise as a result of the public hearing.

Listed below are the standards by which the Appeal Board is governed in making decisions:

- (a) **Practical difficulties or unnecessary hardships do exist.**
- (b) **The variance will not be detrimental to adjacent properties, or to the surrounding neighborhood.**
- (c) **The variance is in harmony with and serves the general intent and purpose of this Ordinance.**
- (d) **Alleged hardships or practical difficulties include more than personal inconvenience and financial hardship. The possibility of increased financial return shall not of itself be deemed sufficient to warrant a variance.**

Signature of Applicant /Owner

8-17-12
Date



Signature of Zoning Administrator/Building Inspector

8-20-12
Date

MORTGAGE INSPECTION

THIS DOES NOT CONSTITUTE A BOUNDARY SURVEY

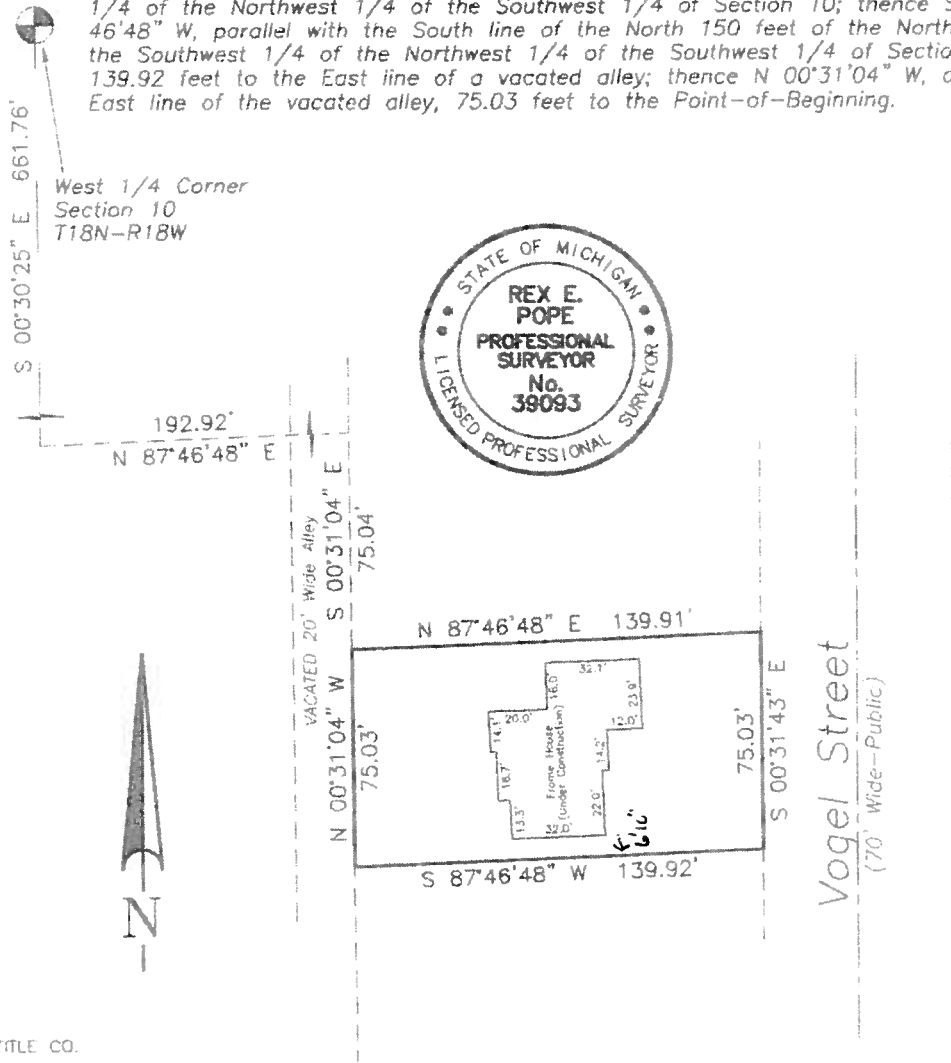
DESCRIPTION FURNISHED: Part of Lots 31, 32 and 33, Block 1, according to the recorded plat of ASSESSOR'S PLAT OF SIXTH ADDITION to the City of Ludington, being in the North 150 feet of the North 1/2 of the Southwest 1/4 of the Northwest 1/4 of the Southwest 1/4 of Section 10, Township 18 North, Range 18 West, City of Ludington, Mason County, Michigan more fully described as Commencing at the West 1/4 corner of Section 10; thence S 00°30'25" E, along the West line of Section 10, 661.76 feet; thence N 87°46'48" E, parallel with the North line of the North 150 feet of the North 1/2 of the Southwest 1/4 of the Northwest 1/4 of the Southwest 1/4 of Section 10, 192.92 feet to the East line of a vacated alley; thence S 00°31'04" E, along the East line of the vacated alley, 75.04 feet to the Point-of-Beginning; thence N 87°46'48" E, parallel with the North line of the North 150 feet of the North 1/2 of the Southwest 1/4 of the Northwest 1/4 of the Southwest 1/4 of Section 10, 139.91 feet to the West right of way line of Vogel Street as platted; thence S 00°31'43" E, along the West right of way line of Vogel Street, 75.03 feet to the South line of the North 150 feet of the North 1/2 of the Southwest 1/4 of the Northwest 1/4 of the Southwest 1/4 of Section 10; thence S 87°46'48" W, parallel with the South line of the North 150 feet of the North 1/2 of the Southwest 1/4 of the Northwest 1/4 of the Southwest 1/4 of Section 10, 139.92 feet to the East line of a vacated alley; thence N 00°31'04" W, along the East line of the vacated alley, 75.03 feet to the Point-of-Beginning.



TITLE CO.

BORROWER

John Wellington Fisher IV

PROPERTY ADDRESS: 1011 Vogel St.

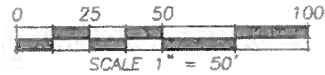

**LAKESHORE
LAND SURVEYING** inc.

6008 BRYANT ROAD
LUDINGTON, MICH. 49631
Phone (231) 843-8885
Fax (231) 843-9058

I HEREBY CERTIFY TO NORTHWESTERN MORTGAGE CO. AND OR ITS SUCCESSORS AND ASSIGNS THAT ON THE ABOVE DESCRIBED PARCEL OF LAND THAT THE EXISTING BUILDINGS AND SUBSTANTIAL VISIBLE IMPROVEMENTS ARE AS SHOWN AND THAT THERE ARE NO ENCROACHMENTS UNLESS OTHERWISE INDICATED.

REX E. POPE PS# 39093

DATE: 8/16/12

File # 120060

Lakeshore Land Surveying , Inc.

6008 Bryant Road
 Ludington, MI 49431
 Ph (231) 843-8225
 Fax (231) 843-9056

INVOICE

DATE	INVOICE #
8/16/2012	14679

BILL TO			
Northwestern Mortgage Company 625 S. Garfield Avenue Traverse City, Michigan 49686 Attn. Jean			
	TERMS		JOB NUMBER
	Due on receipt		120060
DESCRIPTION		AMOUNT	
Mortgage Inspection for: John Wellington Fisher IV Section 10, T18N-R18W City of Ludington, MI		200.00	
It's been a pleasure working with you!		Total	\$200.00
Net Due on Receipt Overdue Accounts will be charged 1.5% / Month on all overdue amounts			

Sheet 4 of 4
Debbie Reed

Legal Description Parcel No. 3

Part of Lots 31, 32 and 33, Block 1, according to the recorded plat of "Assessor's plat of Sixth Addition to the City of Ludington being in the North 150 feet of the North One-half of the Southwest One-Quarter of the Northwest One-Quarter of the Southwest One-Quarter of Section 10, T. 18N., R. 18W., City of Ludington, Mason County, Michigan more fully described as COMMENCING at the West One-Quarter Corner of Section 10; Thence S00° 30' 25"E, along the West Line of Section 10, 661.76 feet; Thence N87° 46' 48"E, parallel with the North line of the North 150.00 feet of the North One-half of the Southwest One-Quarter of the Northwest One-Quarter of the Southwest One-Quarter of Section 10, 192.92 feet to the East Line of a vacated Alley; Thence S00° 31' 04"E, along the East Line of the vacated Alley, 75.04 feet to the **POINT OF BEGINNING**;

Thence N87° 46' 48"E, parallel with the North line of the North 150.00 feet of the North One-half of the Southwest One-Quarter of the Northwest One-Quarter of the Southwest One-Quarter of Section 10 139.91 feet to the West Right of Way Line of Vogel Street as platted;

Thence S00° 31' 43"E, along the West Right of Way Line of Vogel Street, 75.03 feet to the South Line of the North 150.00 feet of the North One-half of the Southwest One-Quarter of the Northwest One-Quarter of the Southwest One-Quarter of Section 10

Thence S87° 46' 48"W, parallel with the South line of the North 150.00 feet of the North One-half of the Southwest One-Quarter of the Northwest One-Quarter of the Southwest One-Quarter of Section 10, 139.92 feet to the East Line of a vacated Alley;

Thence N00° 31' 04"W, along the East Line of the vacated alley, 75.03 feet to the **POINT OF BEGINNING**. Containing 0.24 acres of land.

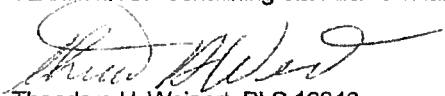
Theodore H. Weinert, PLS 19846



CERTIFICATE OF SURVEY

DESCRIPTION OF PROPERTY FURNISHED

SIXTH ADDITION, NORTH 150 FEET OF THE N 1/2 OF THE SW 1/4 OF THE NW 1/4 OF SW 1/4 OF SECTION 10, T.18N., R.18W., CITY OF LUDINGTON, EXCEPT ALL THAT PART OF THE NORTH 150 FEET OF THE N 1/2 OF SW 1/4 OF NW 1/4 OF SW 1/4, SECTION 10 WHICH LIES EAST OF THE EAST LINE OF VOGEL STREET. BEING ALL OR PART OF LOTS 8, 9, 10, 11, 30, 31, 32 AND 33, BLOCK 1, EXCEPT VOGEL STREET AS PLATTED.

SEE SHEET 1 OF 4
FOR SECTION INFORMATION

SEE SHEETS 3 AND 4
OF 4 FOR LEGAL
DESCRIPTIONS

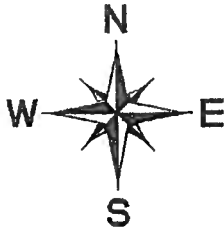

SEE SHEET 1 OF 2 FOR BLOCK SURVEY

SCALE 1"=60'

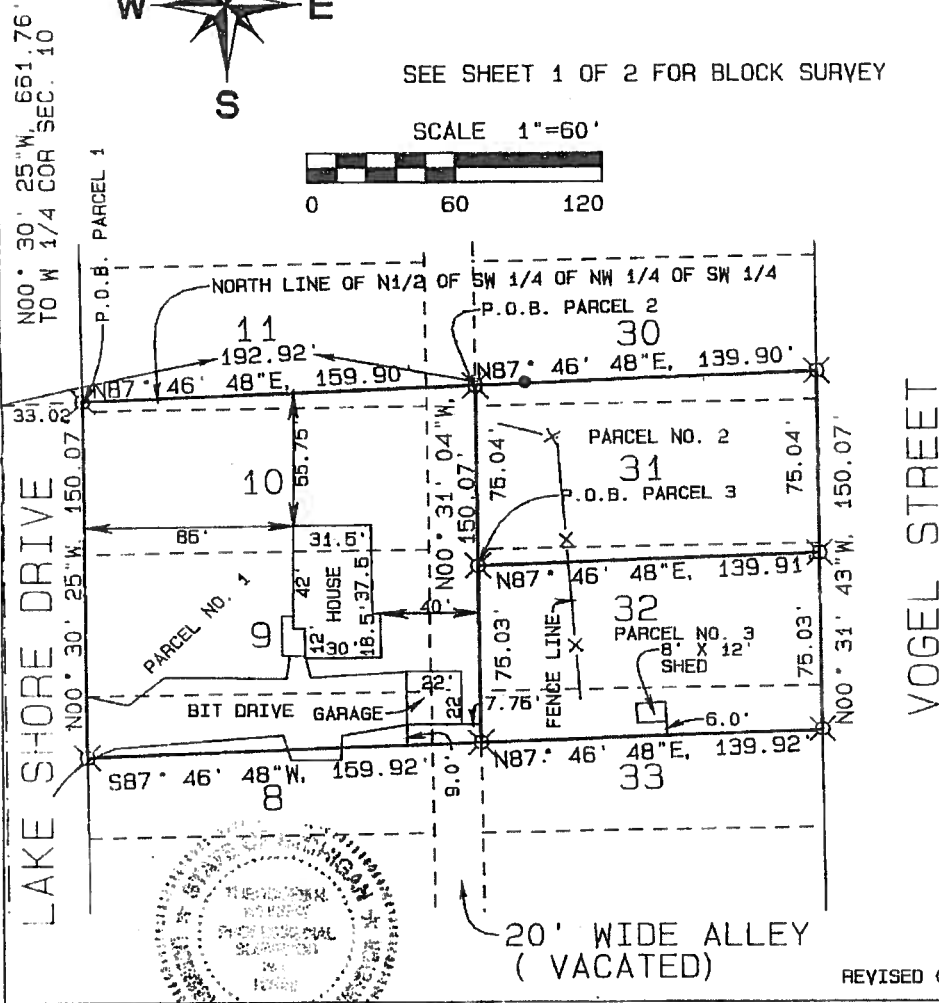
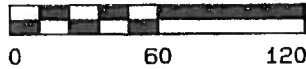

REVISED 04/05/2011

I, Theodore H. Weinert, Registered Land Surveyor in the State of Michigan, HEREBY CERTIFY, that I have surveyed the parcel (s) of land described and delineated hereon; that said plat is a true representation of the survey as performed by me, and that there are no encroachments other than shown hereon; that the ratio of closure of the unadjusted field observations was within the accepted limits; and that I have fully complied with the requirements of Act 132 of Public Acts of 1970, as amended.

Theodore H. Weinert
THEODORE H. WEINERT, PLS 19846

TW LAND SURVEYING, LLC
133 S. MAIN, SUITE 2
P.O. BOX 115
SCOTTVILLE, MI., 49454
PHONE: 231-767-9063
FAX: 231-767-2763
CELL: 231-690-3022

COMPLETED FOR:
DEBBIE REED
CARRIAGE HOUSE REAL ESTATE
5492 W. US 10
LUDINGTON, MI., 49431

DATE: 04/11/2009 Survey By: T.W.
JOB NO: 004-09 Drawing By: T.W.

SHEET 2 OF 4

CERTIFICATE OF SURVEY

DESCRIPTION OF PROPERTY FURNISHED
 SIXTH ADDITION, NORTH 150 FEET OF THE N 1/2 OF THE SW 1/4 OF THE NW 1/4
 OF SW 1/4 OF SECTION 10, T.18N., R.18W., CITY OF LUDINGTON, EXCEPT ALL
 THAT PART OF THE NORTH 150 FEET OF THE N 1/2 OF SW 1/4 OF NW 1/4 OF
 SW 1/4, SECTION 10 WHICH LIES EAST OF THE EAST LINE OF VOGEL STREET,
 BEING ALL OR PART OF LOTS 8, 9, 10, 11, 30, 31, 32 AND 33, BLOCK 1, EXCEPT
 VOGEL STREET AS PLATTED.

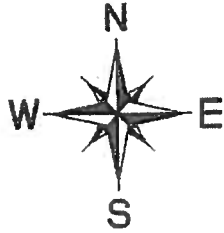
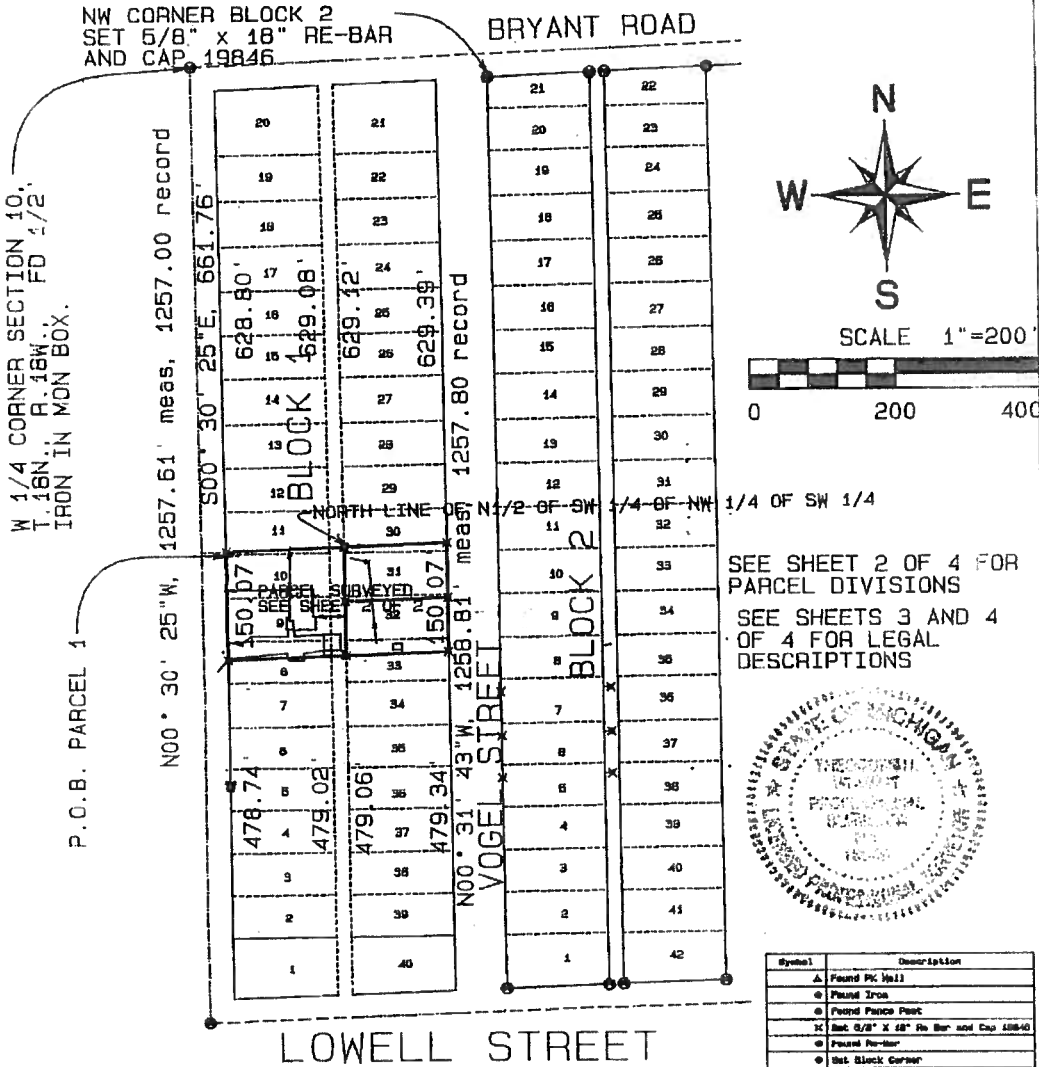

SCALE 1"=200'



SEE SHEET 2 OF 4 FOR
 PARCEL DIVISIONS
 SEE SHEETS 3 AND 4
 OF 4 FOR LEGAL
 DESCRIPTIONS



Symbol	Description
▲	Found Pin Nail
●	Found Iron
○	Found Fence Post
⊠	Set 5/8" X 18" Re Bar and Cap 19846
⊙	Found Re-Bar
⊚	Set Block Corner
-x-	FENCE DO LINE
---	LEADER LINE
---	Section/Quarter Line
---	Property Line
---	Platted Lot Lines

REVISED 04/05/2011

I, Theodore H. Weinert, Registered Land Surveyor in the State of Michigan, HEREBY CERTIFY, that I have surveyed the parcel (s) of land described and delineated hereon; that said plat is a true representation of the survey as performed by me, and that there are no encroachments other than shown hereon; that the ratio of closure of the unadjusted field observations was within the accepted limits; and that I have fully complied with the requirements of Act 132 of Public Acts of 1970, as amended.

Theodore H. Weinert
 THEODORE H. WEINERT, PLS 19846

TW LAND SURVEYING, LLC
 133 S. MAIN, SUITE 2
 P.O. BOX 116
 SCOTTVILLE, MI., 49454
 PHONE: 231-767-9063
 FAX: 231-757-2763
 CELL: 231-690-3022

COMPLETED FOR:
 DEBBIE REED
 CARRIAGE HOUSE REAL ESTATE
 5492 W. US 10
 LUDINGTON, MI., 49431

DATE: 06/23/2009 Survey By: T.W.
 JOB NO: 004-09 Drawing By: T.W.

SHEET 1 OF 4



08/20/2012 08:02



08/20/2012 08:03